

HOW TO PERFORM ROOF INSPECTIONS

This publication is an introduction to the standards and methodology of inspecting a roof. It covers common roof terms, gutters and drainage systems, framing and trim, roof coverings, roof flashings and ventilation, and a brief section on inspecting chimneys.

This guide also serves as a handy on-the-job reference manual for home inspectors, as well as a study aid for InterNACHI's *How to Perform Roof Inspections* online course and exam.

Authors: **Gerry Beaumont**, Founding Chairman
Committee for Online Education
International Association of Certified Home Inspectors

Ben Gromicko, Director of Education
International Association of Certified Home Inspectors

Nick Gromicko, Founder
International Association of Certified Home Inspectors

Graphics: **Lisaira Vega**, Architect and Graphic Artist
International Association of Certified Home Inspectors

Editor & Layout: **Kate Tarasenko** / Crimea River

To order online, visit: www.InspectorOutlet.com



© Copyright 2009-2013 International Association of Certified Home Inspectors

All rights reserved.

HOW TO PERFORM ROOF INSPECTIONS

Table of Contents

Introduction.....	3
The Basics.....	7
Gutters and Drainage.....	17
Framing and Trim.....	25
Roof Coverings.....	36
Roof Flashings.....	78
Roof Ventilation.....	93
Inspecting Chimneys.....	100



Photo courtesy of Kenton Shepard

INTRODUCTION

Exterior Inspection



The roof inspection is both one of the most crucial areas of home inspection and one of the biggest concerns on the prospective home buyer's mind. Spending a large portion of the inspection appointment dealing with the roof and following some basic rules will pay dividends to the inspector, both in terms of customer satisfaction and also in reduced liability.

Before approaching a roof inspection, it's important to keep safety at the forefront. Too many home inspectors and other tradesmen have been seriously injured by being lax with ladder and roof safety.

One of the first safety issues to consider is that some roof systems simply should not be walked on. In particular, most types of solid tile roofs and all wooden shingle and shake roofs can be accidentally damaged by the inspector. In addition, all types of roofs should not be walked on if conditions are wet or icy, or if the roof is mossy (covered in algae), or just too steep.

Even when considering walking a dry roof or a roof of low pitch that's just one floor up, it's important to keep safety in mind. When all other conditions appear favorable and safe, it's still possible to put your foot right through the asphalt shingle roof covering of a house due to rotten roof sheathing.

Remember that, most of the time, a roof covering can be inspected from a ladder at the eaves, from the ground with binoculars, or from overlooking windows.

When planning to walk the roof covering, remember to wear soft-soled sneakers or similar footwear, as they offer a far superior grip compared to work boots, unless those boots are specially designed for walking roofs.

When inspecting the roof using a ladder, keep the following in mind:

- Purchase ladders that are rated for your weight.
- Ensure that the ladder is properly leveled on solid ground.
- Make sure that the ladder is at the correct angle to the wall.
- Pay attention to what the ladder is leaning against, as it is easy to mark siding or damage guttering if you're not careful.
- Consider buying electricians' ladders and steps, as these are made of non-conductive fiberglass and will protect you from shocks, should you hit any un-insulated electrical components, such as service conductors.

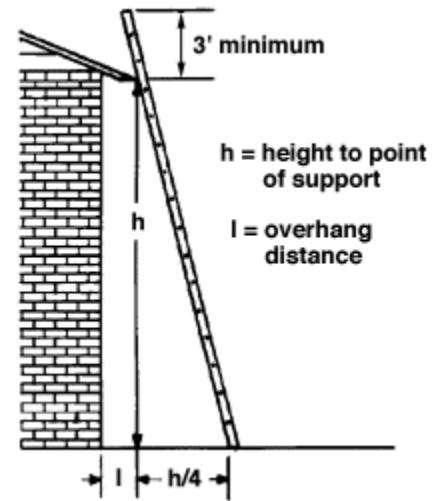

Think safety; clients are not too impressed with inspectors landing in the shrubbery, writhing in agony!

Ladder Setup Tip

To determine whether your ladder is placed safely and properly, follow these tips, courtesy of InterNACHI member David Lane of Texas:

1. Lean the ladder against the building.
2. Look at the ladder's feet and draw an imaginary line between them. Put your toes up to that line.
3. Stand up straight and hold your arms straight out in front of you. The ladder rung should be just beyond your reach.
4. If you can touch the rung, the ladder is too steep. Move it back and repeat these steps.
5. If the rung is several inches beyond your fingertips, the ladder pitch is too shallow. This is also hazardous because the feet can slip backwards when you are on it, causing you to fall. Move the ladder closer and repeat the procedure.

This is a simple process that takes five seconds and ensures that you are about to climb a ladder that is properly pitched.



Overview and Requirements

Here are the goals when inspecting the roofing system:

- to report on the type of roof covering material;
- to report on the visible condition of the roof covering;
- to inspect and report on the visible flashings;
- to evaluate the roof drainage and gutter system;
- to report any overhanging tree branches that may have an adverse effect on the roof covering;
- to report on the chimney system;
- to identify any obvious deficiencies of roof penetrations and through-the-roof components and their flashings;
- to report on any visible deficiencies in the underlying structure (for example, swayback ridge beams);
- to report the methods used to inspect the roof (for example, from the eaves with a ladder, or from ground with binoculars);
- to inspect and report on roofing trim, such as rake boards, soffits and fascia boards; and
- to report on any visible roofing problems that can be inspected from accessible areas of the attic, such as signs of sheathing problems, evidence of moisture intrusion, or damaged structural components, such as split rafters and damaged trusses.

It is also important to understand what you are NOT required to do, such as:

- walk on every roof surface;
- report on the future life expectancy of roof coverings and systems;
- warranty the roof;
- inspect most connected components, such as antennae, solar panels, etc.;
- report on underground gutter terminations; or
- inspect the roof framing system, if not readily accessible.

InterNACHI's Standards of Practice for Performing a General Home Inspection specify the following with regard to evaluating residential roofs:

3.1. Roof

I. The inspector shall inspect from ground level or the eaves:

- A. the roof-covering materials;
- B. the gutters;
- C. the downspouts;
- D. the vents, flashing, skylights, chimney, and other roof penetrations; and
- E. the general structure of the roof from the readily accessible panels, doors or stairs.

II. The inspector shall describe:

- A. the type of roof-covering materials.

III. The inspector shall report as in need of correction:

- A. observed indications of active roof leaks.

IV. The inspector is not required to:

- A. walk on any roof surface.
- B. predict the service life expectancy.
- C. inspect underground downspout diverter drainage pipes.
- D. remove snow, ice, debris or other conditions that prohibit the observation of the roof surfaces.
- E. move insulation.
- F. inspect antennae, satellite dishes, lightning arresters, de-icing equipment, or similar attachments.
- G. walk on any roof areas that appear, in the opinion of the inspector, to be unsafe.
- H. walk on any roof areas if it might, in the opinion of the inspector, cause damage.
- I. perform a water test.
- J. warrant or certify the roof.
- K. confirm proper fastening or installation of any roof-covering material.

The Standards can be read in their entirety at www.nachi.org/sop.htm



THE BASICS

Roof coverings are usually quoted for installation "by the square." A building square is an area of 100 square feet, or 10 feet by 10 feet—this is the finished area.

Roof coverings are also measured by their weight per square. This is an important consideration when a professional or structural engineer is evaluating whether an existing roof structure is capable of carrying the extra load of multiple layers of roof coverings. Generally, a roof with more than two layers of covering is likely to be overloaded and, therefore, many jurisdictions limit the number of layers of covering.

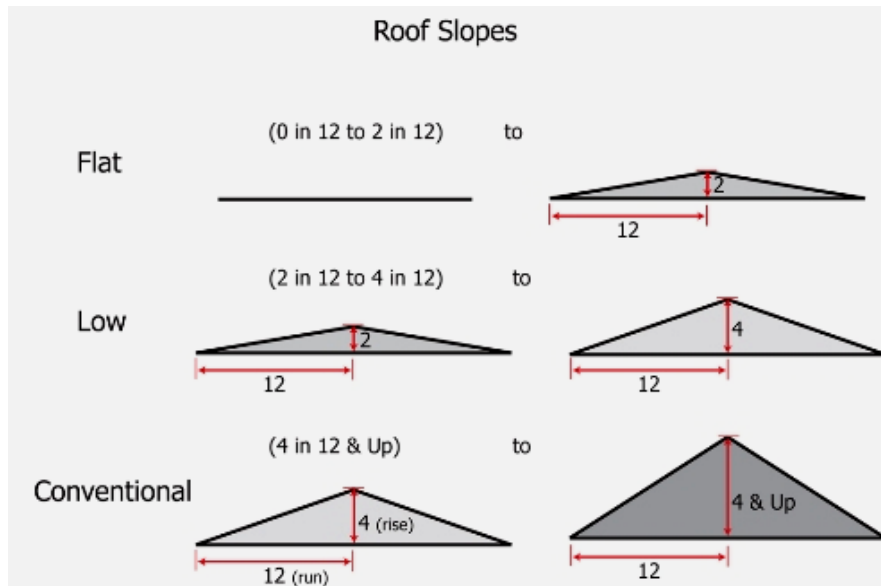

Measuring Slope

The angle of the roof above the horizontal is referred to as the slope of the roof, which is expressed as **rise over run** – that is, the number of feet of vertical rise over a horizontal run of 12 feet – which may also be expressed in inches of rise per 12 inches (or 1 foot) of run.

For example, a roof that has a rise of 4 feet over a run of 12 feet has a slope of 4/12 (expressed as a 4&12 sloped roof). A roof with a rise of 12 feet over a 12-foot run has a 12/12 slope, also expressed as a 12&12 sloped roof. This is a 45-degree incline on the roof.

Roof Pitch

Roof pitch is different than slope. Whereas roof slope is expressed as rise over run, pitch is expressed as a fraction based on a roof having a slope of 24&12, which is considered a **full-pitch roof**. So, a roof with a slope of 12/12 (or 12&12) is a 1/2-inch roof. A 4/12 sloped roof would be expressed as a 1/6-pitch, since 4 feet is one-sixth of the full pitch of 24.

Types of Roofs Based on Pitch:

- A roof with a pitch lower than 2 /12 (or 2 feet of rise in 12 feet of run) is classified as a flat roof.
- A roof with a pitch between 2 /12 and 4 /12 is called a low-rise or low-slope roof.
- A roof with a pitch of over 4 /12 is considered a conventional roof.
- Any roof with a pitch of more than 8 / 12 is too steep to walk on.

Inspectors will occasionally see some very odd roof pitches, such as a 6½ :12, but these tend to be on older stick-built construction. Most contractors try to avoid these odd pitches, as it makes cutting rafters and other roof framing timbers very difficult.

Generally, the steeper the roof, the better it can shed moisture, and the longer the roof will last.

Asphalt shingles should not be used on a roof lower than a 3 /12, and wood shakes and shingles normally require a pitch of greater than 4 /12. Very low-pitch or flat roofs require a continuous surface, such as roll, built-up or membrane roofing. This will be covered in more detail in the section on types of roof coverings.

Roof Pitch and Slope Requirements

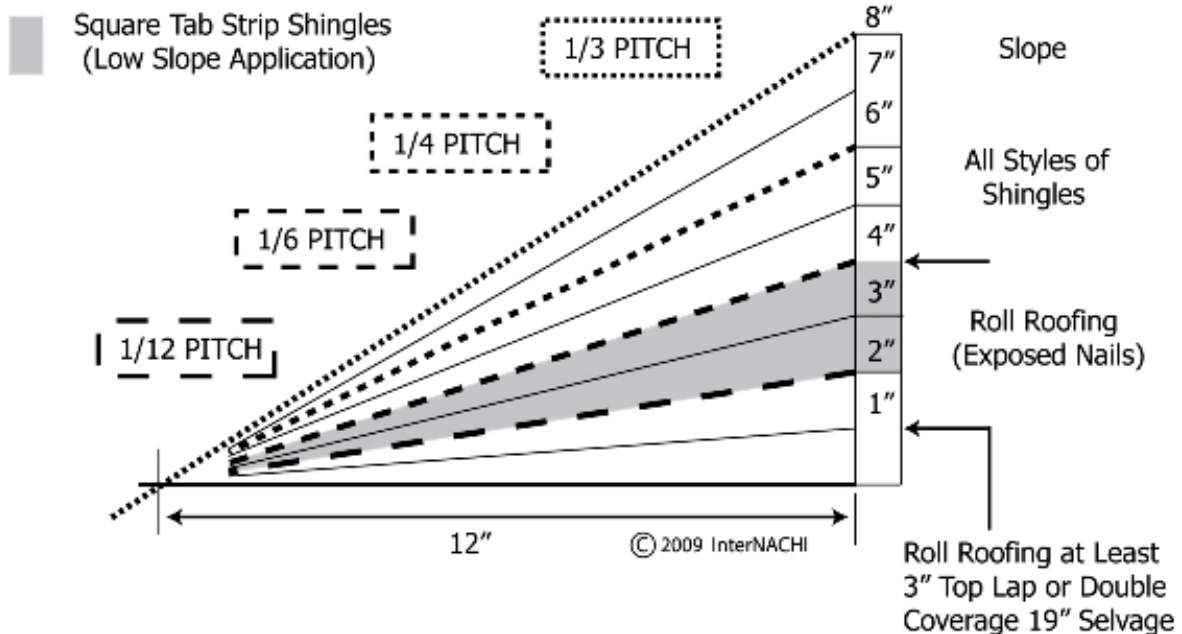

In the diagram above, note that the horizontal figure is 12 inches. This represents the run. The numbers listed to the right, from 1 inch to 8 inches, represents the rise. As the chart shows, a 2&12 roof slope is equal to a 1/12-pitch; a 4&12 roof slope equals a 1/6-pitch; a 6&12 slope equals a 1/4-pitch; and an 8&12 slope equals a 1/3-pitch roof.

Other comparisons of slope and pitch are as follows:

SLOPE	PITCH
1/2 /12	1/48
1/12	1/24
2/12	1/12
3/12	1/8
4/12	1/6
6/12	1/4
8/12	1/3
10/12	5/12
12/12	1/2
14/12	7/12
16/12	2/3
18/12	3/4
20/12	5/6
22/12	11/12
24/12	1

Slope vs. Pitch

There are problems with these two systems:

- Most roofers are unaware of the difference between roof slope and roof pitch and use the terms interchangeably, when they really are referring to a roof's slope.
- Roof pitch is difficult to express when the slope dips below 1 inch per foot.
- Although they are both expressed differently (4&12 slope vs. 1/6-pitch), they are often and easily confused, since both are written in shorthand as a fraction.

In practice, most roofers are concerned with slope (rise over run), while architects and carpenters tend to deal with pitch. It is useful for inspectors to be aware of the two different systems in order not to be confused by them, even though the terms are used interchangeably by many.

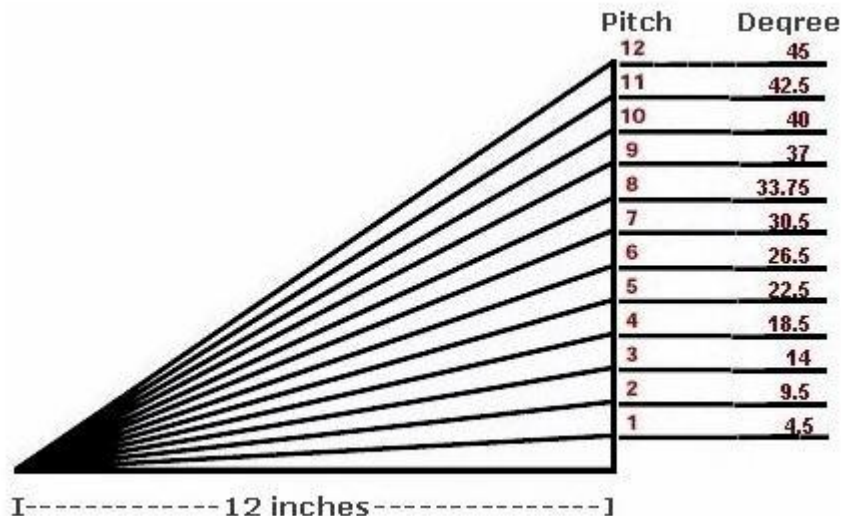

ROOFING STYLES AND DETAILS

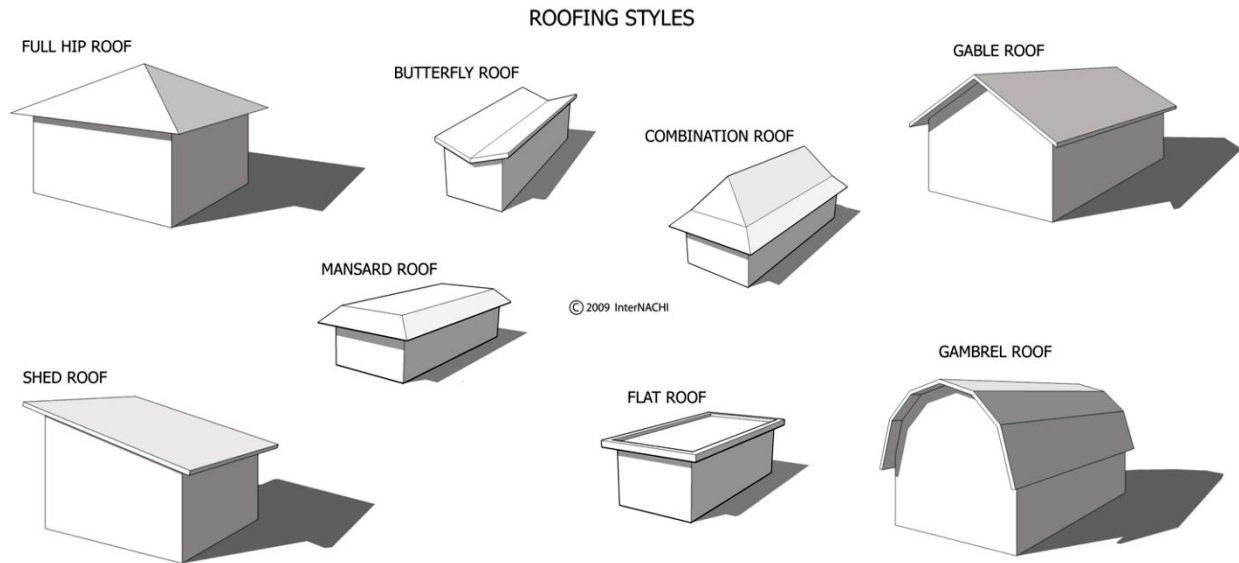

When reporting on the roof or other systems, it is important to use the proper terminology and include accurate locations.

Inspectors should get into the habit of using standard locating verbiage, for example: "left side of hip roof when viewed from front," or, better still: "west-facing plane of gable roof." Adopting this vocabulary makes the inspection report more understandable and reduces the number of call-backs from clients seeking further explanations.

Roof Styles:

- A **flat roof** should not be fully flat but pitched down in one or more areas for adequate drainage.
- A **gable roof** has two covered planes with a center ridge. The planes may or may not be of the same pitch, as with the "saltbox" style of home.
- A **gambrel roof** is similar to a standard gable roof, but each of the covered sides has two planes.
- A **hip roof** has four planes and meets either at a point or (more typically) a short ridge beam.
- A **mansard roof** has four pitched planes with steep sides, and either a flat or lower-pitched, upper-most surface.
- A **shed roof** has a single plane, and is the roof most commonly used for additions to existing structures.
- A **butterfly roof** has two planes angled down to the center.

Architectural Details:

- **cupola:** a small square tower built onto the roof's peak
- **turret:** an inverted, cone-shaped roof, as one would find on top of a tower structure
- **pinnacle:** a decorative feature atop a cupola or turret; quite often, the location for a weather vane
- **dormers:** small-roofed projections perpendicular to the plane on which they sit
- **widow's walk:** a viewing area typically atop the roof of a coastal home, sometimes a cupola-like open structure, historically named for a place to watch for ships returning from sea



Above: a home in Montreal with a tower, dormers, turret and pinnacle

COMMON ROOF ISSUES

There are many factors that can influence the life expectancy of the roof sheathing and covering.

Average Service Lifespan of Roof Coverings	
Material Type	Projected Lifespan
asphalt shingle (3-tab/standard)	20 years
asphalt shingle (architectural)	30 years
roll roofing	less than 10 years
built-up roofing (BUR)	30 years
single-ply membrane roofing	15 to 25 years
wood shakes and shingles	30 years
clay/concrete tiles	100+ years
asbestos cement shingles	25 to 50 years
slate roofs	60 to 150 years
metal roofing (shingle and sheet)	40 to 80 years

Note that the average projected lifespan can be significantly reduced by other factors.

Flat Roof Defects

All roof coverings, regardless of materials, are susceptible to additional variables, such as:

- weather;
- impact damage;
- environmental conditions;
- orientation;
- ventilation;
- insulation;
- structural issues; and
- installation defects.

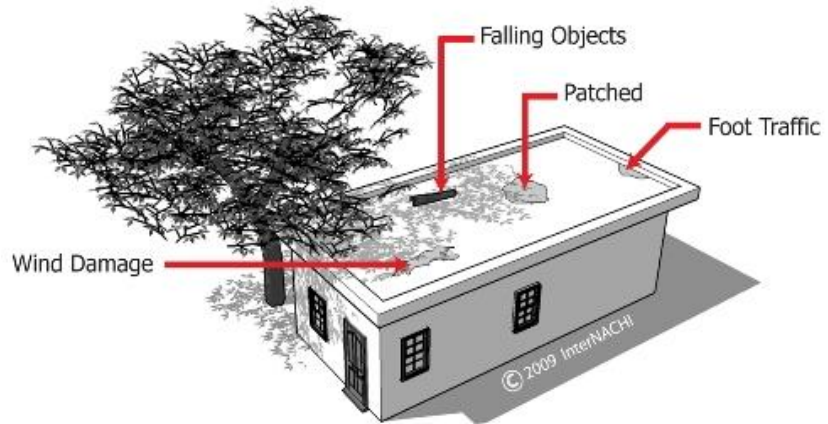

Weather

We have all seen pictures on the news of homes in "Tornado Alley" -- the geographic region that lies between the Rocky Mountains and the Appalachian Mountains -- with their roofs blown off, but it is not unusual to see weather damage in all areas of the United States, as well as in various regions around the world. Sometimes, severe weather damage will leave behind ripped shingles and dislodged tiles affecting just one or two areas of a home's roof but, occasionally, there can be more widespread damage that is easier to spot.



Above: a fiberglass asphalt shingle roof whose shingles became brittle over time, allowing the wind to get under them and blow them off the roof

Impact Damage

This is very common and most often caused by overhanging tree branches. It can also be inflicted by falling masonry, and cracked tiles and shingles from people being on the roof.



Above: damage caused by tree branches

Environmental Conditions

This category of rapid deterioration of the roof covering can be attributed to airborne pollutants that are prevalent in industrial areas, as well as from the acidity of pine needles breaking down on the roof's surface.

Orientation

The direction that the roof faces can have a significant influence on the long-term condition of the roof. For example, south-facing roof planes tend to show signs of overheating, particularly those with asphalt shingles. North-facing roofs and those in the shade tend to have more algae- and moss-induced problems, both of which will shorten the life of the roof covering.



Above: an asphalt shingle roof that shows evidence of overheating, probably caused by both orientation and poor ventilation

Ventilation

Poorly vented roofs, especially those over cathedral ceilings which are hard to ventilate, will show signs of overheating, and may also show signs of moisture damage.

Insulation

Inadequately insulated attics will also promote rapid failure of the roof covering due to issues such as ice damming in colder climates.

Structural Issues

Both the roof sheathing and framing can sometimes indicate structural issues revealed on the roof's surface. Such problems may be as apparent as cracked shingles or tiles above a structural defect. More commonly, there will be a wavy look to the roof caused by thin roof sheathing that is over-spanned.



Above: impact damage on a clay tile roof showing broken and dislodged tiles

Installation Defects

All roofing systems are only as good as the installer, and it is not uncommon to see all types failing due to poor fastenings or other installation problems.

QUIZ 1

1. A roofing square covers an area of _____ square feet.
 - 144
 - 100
 - 10

2. In most jurisdictions, a maximum of _____ layers of roofing is allowed.
 - two
 - three
 - five

3. Roof slope = _____
 - rise / run
 - run / slope
 - run / rise

4. A roof with a pitch or slope of 3/12 is considered a _____ roof.
 - low-slope
 - flat
 - steep-pitch

5. T/F: InterNACHI's Standards of Practice require that all roofs be walked.
 - True
 - False

6. An inspector is not required to report on the _____.
 - guttering system
 - roof covering
 - TV antennae
 - condition of covering

(continued)

7. T/F: The inspector is not required to report on tree limbs overhanging the roof surface, since they are not part of the structure.

- True
- False

8. A flat roof is one with a pitch or slope of less than _____.

- 1/12
- 2/12
- 12/12

9. A standard gable roof has _____ plane(s).

- four
- two
- one

10. A roof with four planes meeting at the ridge is termed a _____ roof.

- hip
- Dutch
- mansard

11. Standard 3-tab asphalt shingles generally last _____ years.

- 20
- 50+
- 40

12. T/F: Slate roofs can last forever.

- True
- False

Answer Key is on the next page.



Answer Key to Quiz 1

1. A roofing square covers an area of 100 square feet.
2. In most jurisdictions, a maximum of two layers of roofing is allowed.
3. Roof slope = rise / run
4. A roof with a pitch or slope of 3/12 is termed a low-slope roof.
5. T/F: InterNACHI's Standards of Practice require that all roofs be walked.
Answer: False
6. T/F: An inspector is not required to report on the TV antennae.
Answer: True
7. T/F: The inspector is not required to report on tree limbs overhanging the roof surface, since they are not part of the structure.
Answer: False
8. A flat roof is one with a pitch or slope of less than 2/12.
9. A standard gable roof has two plane(s).
10. A roof with four planes meeting at the ridge is termed a hip roof.
11. Standard 3-tab asphalt shingles generally last 20 years.
12. T/F: Slate roofs can last forever.
Answer: False

GUTTERS AND DRAINAGE



Effective roof drainage is a must for two reasons. First, the roofing system needs to drain quickly so that large volumes of water are not trapped on the surface. Second, water runoff from the roof needs to be managed so that it is not being directed toward the foundation.

Guttering systems, like everything else, have evolved greatly over the last couple of hundred years, starting out as crude wooden troughs and ending up with the vinyl and metal systems that we use today. It is fair to say that most guttering systems are high-maintenance. Homeowners with conventional uncovered gutters are required to regularly clean out vegetation and debris that get blown into them. Gutters often need to be re-fitted when severe weather detaches them from the fascia.

Technically speaking, roofing gutters should slope down toward the downspout at the rate of 1/16-inch per foot, or 1/4-inch per 5 to 10 feet. An angle less than this won't allow water to move effectively, and much more of an angle will cause the water to move at too great a speed, potentially resulting in overflow over end caps and corners.

In terms of standards, no inspector is going to actually measure the amount of slope. To do it accurately would be time-consuming, would require a transit or water level, and would exceed InterNACHI's Standards of Practice.

A more practical approach is to make sure that all gutters slope toward the downspout. In judging adequate slope, look for signs of standing water in portions of the gutter away from the downspout, and eyeball the margin against the fascia. It is not uncommon to see gutters installed too low on the fascia, or to see roof coverings projecting too far over the gutter. In both cases, this may lead to the water over-shooting the gutters completely. Typical gutter systems hold up better when the brackets are spiked or screwed through the fascia and into the ends of the rafters, and not just into the 3/4-inch fascia board.

In this section, we'll look at the various types of gutters and their common weaknesses, as well as their materials, installation and maintenance. It bears mentioning that it is difficult to evaluate the guttering systems without also looking at the site drainage immediately surrounding the house, and this topic is covered in other InterNACHI books and online courses dealing with a home's exterior.

Guttering Types and Materials

No Gutters

Not all homes were designed to have gutters. In some areas of the United States, they are deemed unnecessary due to very low rainfall. Even in areas with higher rainfall, some homes were designed with a long eave overhang (as much as 4 or 5 feet) to direct water away from the foundation. However, it does not always have the desired effect.

Yankee Gutters

These are little more than diverters directing water away from specific areas of the structure, particularly over doorways and entrances. Sometimes, they are also installed to protect other areas, such as the eaves. Yankee guttering was the earliest form of water management. On some very old homes, there are still planks held in place by wooden blocks. Normally, they were lined with tar to both protect the gutter and to seal it to the roof. The modern version of Yankee guttering is a metal type that is still seen on new construction directly over entryways.



Above: a Yankee gutter being installed together with its metal flashing. The earliest Yankee gutters had no flashing at all.



Above: a section of redwood gutter whose timber is prized for its resistance to weather and insects

Wooden Guttering

Wooden guttering is still fairly common. It was still being installed as recently as the 1930s. Originally, it consisted of little more than wooden troughs, but these were later milled out of close-grain timber and are very similar in profile to modern metal and vinyl systems. In many cases, they were lined either with tar or with metal, such as lead, copper or aluminum.

Generally speaking, most older systems still in operation have not been well-maintained. When they start to rot, any moisture is transferred straight into the fascia, soffit and rafter tails.

Cornice or Gully Guttering

Cornice or gully guttering is an integral part of the roof system. Typically, the guttering was laid down with the roof framing and sheathing, and then covered with metal or roll roofing running up under the roof covering. The downspouts are often hidden inside posts and pillars to mask their presence. When these fail or when the downspouts become blocked, they can wreak havoc on the roof structure. Most of these systems have now been built over, and normal fascia-applied guttering has been installed.



Above: a section of cornice guttering with visible rot; notice the downspout hidden within the column

Metal and Vinyl Guttering:

- The two biggest problems with **steel** guttering are rust, if not properly maintained, and the potential for leaks in any joints and downspout connections. Steel guttering comes in shorter lengths, so there tend to be many joints in the system -- not just at the corners.
- **Aluminum** guttering is quite often formed on-site from a roll of sheet aluminum. This leads to fewer joints, but those at corners and downspout connections should still be fully evaluated.

The most common method of connecting the components is using aluminum pop-rivets. These very frequently fail, either from impact damage or building movement.

- **Copper** guttering was becoming a lost art until recently, but it is reappearing on both high-end new construction and on quality restorations of older properties. What makes copper systems desirable is that all of the joints are soldered, including those of the downspouts. This tends to make for a system with a long lifespan.
- **Vinyl** guttering is not only very common on new construction, but is also the do-it-yourselfer's material of choice, as it is available off-the-shelf at most home improvement stores. Prefabricated angles, corners and connections are readily available, and installation requires no special tools, or even technical aptitude.



Above: copper guttering in new construction; note the copper drip edge.



Above: standard vinyl guttering, properly installed



Above: The downspout has separated from the rusted steel guttering.

Common Gutter Inspection Issues

Regardless of the material or style, all gutters tend to exhibit common problems and should be inspected primarily the same way.

Here's what to look for when evaluating guttering:

- Does the gutter slope downward at a minimum of 1/16-inch per foot?
- Are there downspouts present?
- Is there an adequate number of downspouts?
- Is the guttering securely fastened to the building?
- Are brackets missing?
- Are gutter spikes backing out?
- Can you see signs of leaking from the joints?
- Are the gutters blocked by debris, or even rooted vegetation?



Finally, take a good look in the bottom of the gutters. The contents will typically point to roof covering problems. For example, if there is a large amount of asphalt shingle aggregate in the gutter, as in the photo at left, that's a sign that the roof covering is likely nearing the end of its lifespan.

DOWNSPOUTS AND TERMINATIONS

Downspouts

Every square inch of downspout is capable of discharging drainage for 100 square feet of roof surface. Therefore, a 2x3-inch downspout can handle 600 square feet of roof, and a 3x4-inch downspout can manage 1,200 square feet.

Most downspouts are made of the same material as the gutter system, so they tend to suffer from similar problems, but with a few twists -- especially in the area of mechanical damage from proximity to high-traffic areas.

Inspect the downspouts for:

- the connection between the downspout and the gutter;
- proper attachment of the downspout to the structure;
- leakage in joints (because, sometimes, they will have been installed upside-down);
- impact damage from car doors, etc.;
- downspouts that terminate onto another roof surface, as this will quickly erode the covering at the termination; and
- whether the termination is directing water away from the foundation.

The last checklist item is very important, as it is pointless to have a gutter system that is directing roof water runoff straight down into the foundation. Unless the grade slopes steeply away from the foundation, if the downspout empties too near the foundation, recommend that downspout diverter extensions be installed.

In some areas of the U.S., local conditions dictate that the termination of the downspout system be a minimum of 5 feet from the foundation due to soil conditions.

The downspout below has nothing to deflect the water away from the foundation, resulting in visible erosion of the ground.



The gutter below is pulling away from the fascia; also note the visible rot on the fascia board.



Internal Drainage

Many flat roofs have internal drainage systems. Although they are not common in modern residential construction, they will be found on older homes and many commercial roofs. The drainage system relies on the roof having one or more low points to which runoff water is directed, where it will then run down internal piping connected to the drainage system.



Water is ponding on the roof's surface (above) due to a lack of proper drainage pitch.

The common problems with this system include:

- inadequate slope on the roof (which should be a minimum of 1/4-inch per foot);
- poor flashing between the roof covering and the drain;
- drain blockage due to leaves and other debris;
- failure of the internal pipe system due to pipe corrosion; and
- failure of the building's main foundation drainage system.

Significant structural problems can be caused both by water getting under the roof covering and from systems that have not been draining properly. Snow can also overload the roof structure and contribute to such problems. These systems should have leaf guards installed at the drains to prevent blockage, and they should always be monitored.

Underground Systems

While the inspector cannot be expected to evaluate underground systems, it is worthwhile to have some basic knowledge of the systems and to understand the potential problems. Underground terminations usually connect to one of three systems.



On-site drainage: The gutters connect to subterranean piping that simply takes the runoff to a low area on the property and discharges it to the ground, well away from the foundation.

Above: This is a typical installation of an underground drainpipe terminating to daylight at a low-level area on the property.

Connection to foundation drains: The downspouts in these systems are connected via vertical drains to the home's foundation or drain tile system. This may ultimately be connected to the municipal storm drain system.

French drains and drywells: A pit or channel is dug and lined with a membrane and normally filled with crushed stone. This leaves a lot of airspace in the drywell. When heavy rain is directed into the drain system, it is able to hold a large volume of water until it is able to percolate into the surrounding soil. These systems are most common as a retrofit to alleviate known rainwater problems, and can be very effective.

All underground drain piping can suffer from failures, and while the inspector should disclaim these in his report, it is good to know the potential problems.

The most common issues are:

- piping silting up due to poor separation from soils;
- blockages from leaves and other debris getting into the system;
- root systems from trees and shrubs infiltrating and choking off the pipes; and
- pipes collapsed from vehicles driving over the ground above them.

QUIZ 2

1. **The proper slope for guttering is ____ per foot.**
 - 1/16-inch
 - 1/4-inch
 - 1/2-inch

2. **Gutters should be installed by _____.**
 - screwing or spiking them into the soffit
 - screwing or spiking them into the fascia
 - screwing or spiking them through the fascia and into the rafter tails

3. **T/F: All homes are required to have gutters installed.**
 - True
 - False

4. **T/F: Rusting steel gutters are a cosmetic issue and need not be reported.**
 - True
 - False

5. **Which of the following guttering issues need not be reported?**
 - the presence of leaf guards
 - gutters that slope up from the downspouts
 - missing downspouts

6. **Which of the following is not a guttering material?**
 - steel
 - brass
 - plastic
 - copper
 - aluminum

(continued)

7. T/F: The inspector should report on any debris buildup in the gutters.

- True
- False

8. T/F: The inspector should inspect all visible downspout terminations.

- True
- False

Answer Key to Quiz 2

1. The proper slope for guttering is 1/16-inch per foot.
2. Gutters should be installed by screwing or spiking them through the fascia and into the rafter tails.
3. T/F: All homes are required to have gutters installed.
Answer: False
4. T/F: Rusting steel gutters are a cosmetic issue and need not be reported.
Answer: False
5. Which of the following issues need not be reported?
Answer: the presence of leaf guards
6. Which of the following is not a guttering material?
Answer: brass
7. T/F: The inspector should report on any debris buildup in the gutters.
Answer: True
8. T/F: The inspector should inspect all visible downspout terminations.
Answer: True

FRAMING AND TRIM

ROOF FRAMING FROM THE EXTERIOR

Sagging Ridge due to Inadequate/missing Rafter Ties

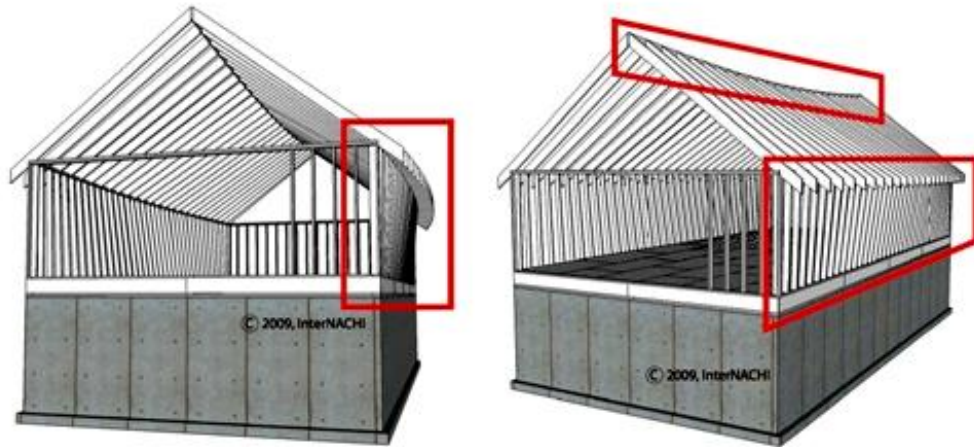

Many roof problems are caused by issues with the framing and sheathing. In this section, we'll focus on the defects that may be viewed from the exterior of the property. This is one of those cases where standing back and taking a good, hard look is better than getting "up close and personal" with the roof.

Ridge Issues

One of the more common things to see, especially on older homes, is what is generally called "saddle" or "swayback." This happens when the ridge beam has settled down toward the center of the roof.

There are several potential causes for this, among them:

- a rotten or broken ridge beam;
- an overloaded roof surface;
- undersized framing members; and/or
- a lack of collar ties.

A noticeable step in the ridge can also indicate more serious problems affecting the whole home structure, such as a footing or foundation problem.

Rafter Issues

Similar to ridge sag, rafters may also be pushed down in the center. Wherever possible, try to get a view along the plane of the roof. There can be many reasons for the rafters bowing.

Here is a list of possibilities:

- undersized rafters;
- roof loads too high;
- a lack of collar ties;
- a lack of purlins or knee walls;
- poorly modified ceiling joists; and/or
- improperly modified roof trusses.

Sheathing Issues

Originally, roof sheathing was made from 3/4-inch to 1-inch planking, but in the 1950s and '60s, it became common to use plywood or particleboard in 8x4 feet sheets laid perpendicular to the roof rafters. It is not uncommon for the roof to have a wavy appearance. This is most often caused by:

- rafters or trusses set too far apart;
- roof sheathing that's too thin;
- moisture-damaged sheathing;
- sheathing that's fitted too closely together; and/or
- sheathing that's missing H-clips.



At left: visible dips due to de-laminating ply sheathing

(Photo courtesy of Richard Moore)

At right: Notice the ridgeline changing angle at the right side above the door, which was caused by a cracked ridge beam.

(Photo courtesy of Dave Valley)



General Structural Inspection

When inspecting the roof structure from the exterior, the inspector should also pay close attention to the wall structures. If the roof system shows signs of any of the problems listed previously, then you may also observe possible signs of the walls bowing out, or the soffits pulling away from the tops of the walls. This is a condition called rafter spread, where the weight of the roof, which is under compression, has pushed the roof rafters outward, resulting in a separation of the roof structure from the walls, and pushing the top of the walls outward.



This wall (at left) was actually being pushed over after a fire had collapsed the roof. Visible at the top is rotation of the wall structure.

ROOFING TRIM

Any wooden trim associated with the roof system is susceptible to rot and, in some cases, insect damage. It is an area that should be fully inspected either from the ground or from a ladder, if possible.

Remember that ladder safety is a priority. Be careful when inspecting roofing trim. Also, be careful if you are allergic to insect bites and stings. Soffits, gables and fascia boards can literally be a "hive of activity."

Fascia

The horizontal board enclosing the ends of the rafter projections (or tails) is referred to as the fascia board, and if gutters are attached, they are fitted here. Because the fasciae are at the lowest point of the roof plane, they often act as sponges for any misdirected moisture. Rotting fasciae can also be masking a lot of rot in the rafter tails, which can be very expensive to replace.

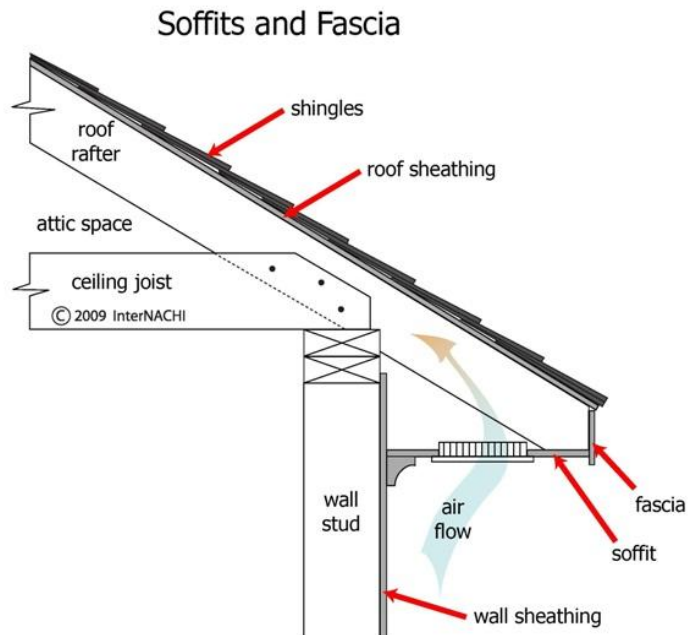

Rake or Barge Boards

These are the boards that cover the ends of the roof structure from the fascia to the ridge. Like the fascia boards themselves, they are known to rot, especially at the lower ends.

Soffits

The soffit is the area underneath the eaves or rafter tails that is normally enclosed at the front by the fascia boards. There are three main types of soffit:

- open soffits, with no bottom enclosure;
- closed soffits, where the soffit board is fastened directly to the underside of the rafter tails; and
- box soffits, where the soffit board extends at a right angle from the wall to the end of the rafter tail.

As with the fascia boards, the soffit, placed at the low point of the roof structure, is a typical area for rot. Common causes include water penetrating the roof covering and migrating down the sheathing, ventilation problems, and ice damming. Carefully inspect these items, and report any damp or rotten-looking areas.



*At left: standard box soffit showing signs of de-lamination due to moisture intrusion
(Courtesy of Mike Rose)*



At left: older-style enclosed soffit clearly showing holes and missing boards, as well as signs of moisture in the roof sheathing

At right: open soffit with visible signs of moisture staining on the underside of the roof sheathing



At left: rot in the lower part of the rake board; the wood has swollen and is pulling away.

(Photo courtesy of Erby Crofutt)

Drip Edges

Many of the problems with wooden roofing trim systems can be avoided when a proper drip edge is fitted between the roof decking and the roof covering. This edge protects both the sheathing and the trim by directing water either into the guttering (if fitted), or at least far enough away from the trim that it cannot wick into the wood.

Drip edges should be installed so that the roofing paper or felt is underneath the drip edge on the rake, but over it along the eaves.

Drip Edge Shapes

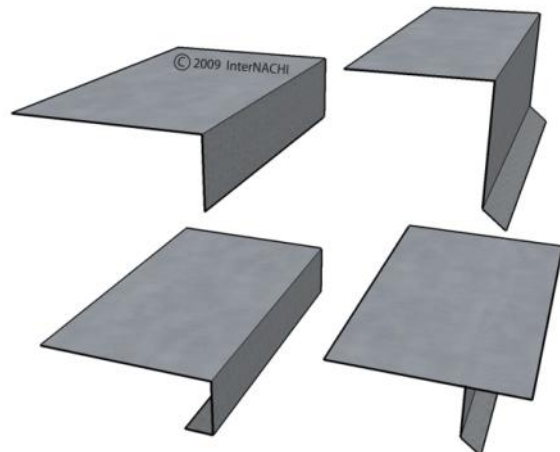



At left: a good example of how a drip edge is designed to direct water away from the fascia

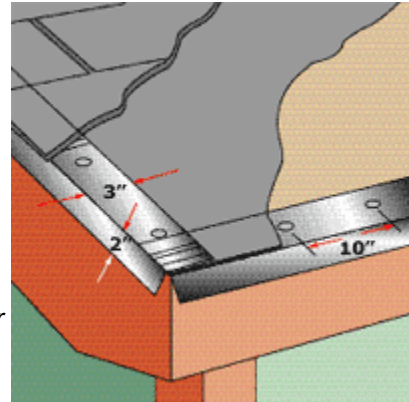

At right: details of roof drip edge showing proper application and nailing pattern

Other Trim Areas and Issues

Any additional decorative trim installed either onto the fascia or at the soffit wall interface is normally referred to as a cornice. These can be as simple as a 1/4-inch round molding, or a larger profile, sometimes including dentil molding. All such trims should be thoroughly inspected for rot and insect damage.

All other wooden trim adjacent to the roof surface should have at least an inch of clearance from the roof covering (and more in snowfall areas). This is particularly important with areas such as the sides of dormers, where water running down the roof can damage the trim and siding.



At left: Wood rot has loosened the cornice molding and is splitting around the nails.



At right: an ornate cornice under a mansard roof with dentil molding



At left: Any trim that is this close to a roof's surface could potentially allow moisture to wick into the structure.

Structural Issues Disguised as Cosmetic Ones

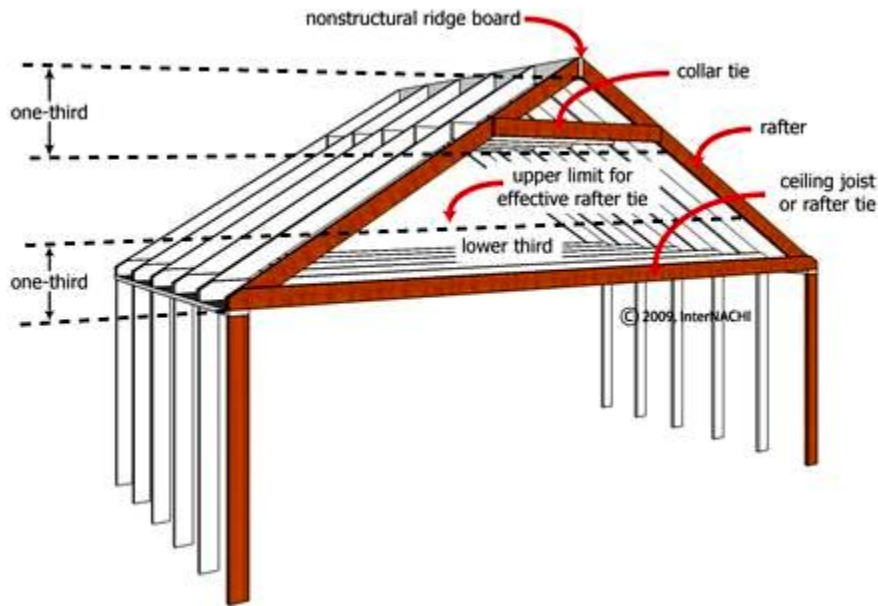

Although diagnosing the causes behind structural and cosmetic defects lies beyond the scope of a home inspector's duties, according to the InterNACHI Residential Standards of Practice, understanding some of those causes can help inspectors recognize certain defects more quickly so that he can report them and make appropriate recommendations to his clients.

One of those defects related to roofs is rafter sag or a bowed interior ceiling that is mistakenly attributed to a lack of collar ties.

Collar ties are designed to resist expansive or an outward movement of force that is usually accompanied by wall spread and ridge sagging. However, they do not prevent rafters from sagging or bowing downward in the middle. That's caused by factors such as over-spanned, under-sized or over-spaced rafters.

Such conditions are also sometimes caused by excessive roof load, such as too many layers of shingles or other roofing-covering material, or a change-out from composition shingles to tile, where the weight is greater than 6 pounds per square foot. Collar ties help prevent roof settlement but not a rafter from sagging in the middle.

(It is possible that when the slope of the roof descends to a lower slope/pitch, the load on the rafters' span shifts somewhat from the seat cut toward the middle of the rafter.)

In the case of rafter sagging, the collar ties themselves become bowed or bent inward, since they are not designed to resist a compressive load. Collar ties resist the outward or expansive motion of the rafters, not compression.

It is the framing members that are designed to withstand both compressive and expansive loads. A lack of collar ties (typically 1x wood) would cause the ridge -- not the rafters -- to sag, as well as cause the walls to spread. They react by simply bowing as they resist the force of expansive or outward movement.

One of the most common mistakes that homeowners and contractors make in remodeling is that they remove the ceiling plaster and joists (to raise the ceiling and gain room volume, etc.), and thereby also remove the ceiling diaphragm, which is a supportive element and can be an integral seismic element of a building. This not only affects the roof framing and wall spread, but it removes a seismic resistive plane of the structure (the ceiling), regardless that lath and plaster or drywall doesn't have much shear value.

What generally happens is that, after removing the ceiling, homeowners and contractors sometimes fail to do one of two things:

1. install the appropriate number and size of collar ties that are typically no more than one-third up toward the ridge plate from the wall plates, so as to prevent ridge sag and wall spread; or
2. remove the ridge plate and install a ridge beam in its place, with the load effectively transferred to the foundation. A ridge plate allows rafters to rest against it but does not carry a vertical load. The triangle formed by the rafters and ceiling transfers the load to the walls of the house. (Contrariwise, the ridge beam transfers the vertical load of the rafters and roof system directly to the foundation, where it is concentrated. Sometimes, an additional footing is required under that portion of the foundation to support the additional load presented.)

Another issue is that a homeowner or contractor may add drywall to the underside of the rafters, thereby increasing the load on them and causing ventilation problems, which can, in turn, cause condensation and moisture problems, resulting in mold growth, rafter rot, etc.

An inspector who observes a sagging rafter in an unfinished attic, a sagging or bowed ceiling, or, through infrared imaging, detects heat signatures that may indicate moisture above the ceiling, should note such details in his report and recommend further investigation by a qualified professional who can make any necessary repairs and/or structural corrections.

QUIZ 3

1. Which of the following would not cause rafter spread?

- lack of collar ties
- over-spanned rafters
- adequate knee walls
- too many layers of roof coverings

2. Deflection of the ridge beam is called _____.

- rafter spread
- hogback or horseback
- saddleback or swayback

3. A "step" in the ridge may indicate _____.

- structural problems
- rafter spread
- a lack of purlins

4. A gap between the wall and soffit may indicate _____.

- moisture in the soffit
- rafter sag or spread
- blocked gutters

5. A soffit that is attached directly to the underside of the rafter tails is called a(n) _____ soffit.

- box
- enclosed
- open

6. The clips that are required between many sheathing panels are called ____-clips.

- T
- H
- L

(continued)

7. Roof ridges and rafters are normally under _____.
- deflection
 - tension
 - compression
8. Roof sheathing should be installed _____ to the rafters.
- parallel
 - perpendicular
 - vertical
9. The horizontal board enclosing the ends of the rafter projections (or tails) is referred to as the _____ board.
- cornice
 - fascia
 - soffit
10. A decorative molding applied to the fascia is called a _____.
- cornice
 - barge board
 - dentil molding
11. The distance that should separate the siding from the roof's surface is _____.
- 2 to 4 inches
 - less than 1 inch
 - 1 to 2 inches
12. Drip edge flashing should be installed _____.
- over the roofing paper/felt along the eave edge
 - over the roofing paper/felt along the rake edge
 - under the roofing paper/felt along the rake edge

Answer Key is on the next page.



Answer Key to Quiz 3

1. Which of the following would not cause rafter spread?
Answer: adequate knee walls
2. Deflection of the ridge beam is called saddleback or swayback.
3. A “step” in the ridge may indicate structural problems.
4. A gap between the wall and the soffit may indicate rafter sag or spread.
5. A soffit that is attached directly to the underside of the rafter tails is called a(n) enclosed soffit.
6. The clips that are required between many sheathing panels are called H-clips.
7. Roof ridges and rafters are normally under compression.
8. Roof sheathing should be installed perpendicular to the rafters.
9. The horizontal board enclosing the ends of the rafter projections (or tails) is referred to as the fascia board.
10. A decorative molding applied to the fascia is called a cornice.
11. The distance that should separate the siding from the roof's surface is 1 to 2 inches.
12. Drip edge flashing should be installed over the roofing paper/felt along the rake edge.

ROOF COVERINGS

INTRODUCTION TO ROOF COVERINGS

One of the big problems with inspecting roofs is that there are so many different roofing systems out there, and the inspector is required to know a lot about all of them. While they may appear to have little in common, the basic rules for the inspector remain the same:

- Identify the roof covering material.
- Report on any visible deficiencies.
- Recommend repairs and/or maintenance as needed.
- Don't report on the future life expectancy of the covering.

The different types of roof covering materials reviewed in this section -- along with their history, lifespan, installation methods, and inspection and reporting issues -- include:

- **asphalt shingle;**
- **tile roofing**, including:
 - slate roofs;
 - clay tile roofs;
 - concrete tile roofs; and
 - asbestos cement tile.

- **wooden shingle and shake** (and their differences);
- **roll roofing;**
- **built-up roofing;**
- **membrane roofing;**
- **metal roofing systems**, including:
 - standing seam systems; and
 - metal oddities (shingle, sheet, corrugated).

ASPHALT SHINGLES

Asphalt Shingle Inspection

Asphalt shingles are the most common roof covering that the inspector will see, as they are relatively inexpensive, easy to install, and last between 15 to 40 years, depending on type.

Despite the fact that there are many different styles of asphalt shingles, they are all manufactured and installed in the same way, so they tend to exhibit similar problems over their service life.

Basic Shingle Construction

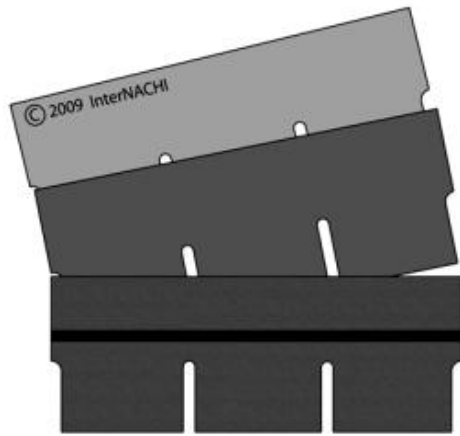

- Base
- Body or Coating
- Surface Granules
- Self-Sealing Strip

All these shingles are made from an asphalt-impregnated mat, either of a cellulose material (for regular shingles) or fiberglass (for fiberglass shingles). The mat is then covered with a heavier layer of asphalt. Finally, a layer of granules is pressed into the surface as protection from ultraviolet light.

The quality of asphalt shingles is in direct proportion to their weight per square (100 square feet). Heavier shingles (up to 350 pounds per square) generally last longer than the lighter shingles (200 pounds per square). The heavier shingles tend to be of the architectural style, with several layers of material.

An inspector needs to be aware that most jurisdictions allow only two layers of shingles to be applied to the roof due to the load considerations. For example, a 15-square area of roof with two layers of average 250-pound shingle has a total weight of covering of 7,500 pounds, or nearly 4 tons of weight.

Asphalt Shingle Installation

The underlayment for asphalt shingle is usually roofing felt with a course of ice and water shield covering the lowest 3 feet. This prevents moisture from backing up under the shingle over the eaves.

The application starts at the bottom of the roof with a single starter course (often, a shingle with the tabs cut off) fixed so that the first proper course is glued at the lowest edge.

This is followed by the regular courses applied so that the joints or gaps between the tabs do not line up with each other, and over three courses to stop water from penetrating the covering. Each shingle has a tar line above the exposed surface which glues the upper shingle to the previous course.

Ridges are capped with either a special tile manufactured for the purpose (as in the case of architectural styles) or, more commonly, trimmed-down shingles prepared on-site by the installer from standard 3-tab shingles.

Asphalt shingles are designed to be installed on roofs with a pitch greater than 4 /12, but some shingles can be installed on roofs as low as 2/12 where proper precautions, such as double underlayment, have been installed, and the shingles themselves have been additionally glued down in accordance with the manufacturer's instructions.



The lowest 3 feet of the roof get a layer of ice and water shield.



Then, a roofing felt is applied, overlapping at the bottom edges.



A starter course is applied to the roof edge which protects the roof from any gaps in the first full course.



At left: After the starter course comes the first full exposed course.



At right: The second course is applied, ensuring that there is a proper side-lap so the joints don't line up.



Here, you can see the side-lap between overlapping shingles.



The joints are staggered all the way up the roof.

Asphalt Shingle Designs

There are many designs and colors of asphalt shingle available.

The basic designs are:

- standard shingle with no decorative features;
- 3-tab shingles, which somewhat ape roof tile; and
- architectural shingles that have added layers of material to mimic the look of slate or shake roofs.

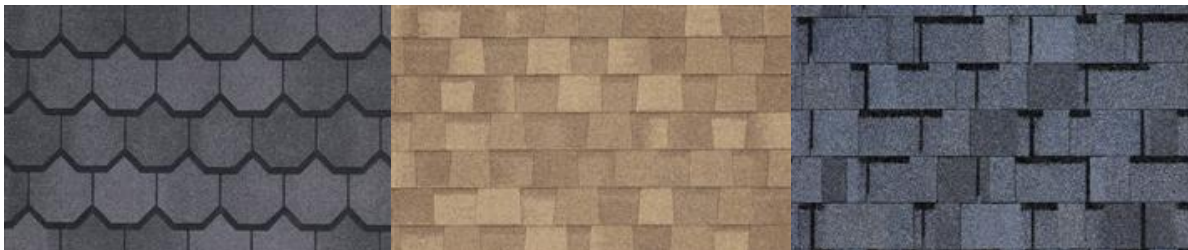

PROBLEMS WITH ASPHALT SHINGLES

All asphalt shingle roofs, regardless of design, will fail due to the following reasons:

- weather issues;
- impact damage;
- debris on the roof;
- poor installation techniques;
- material failures; and
- ventilation problems.

Weather Issues

- **Sunlight** is a big enemy of asphalt roofs. When subjected to the sun's heat, the shingles will dry out due to off-gassing of hydrocarbons in the asphalt, since asphalt is a petrochemical product. This will promote the loss of granules and make the shingle more brittle. As the shingle dries out, it will also shrink, opening up the areas between shingles or between tabs. This may also cause cupping, bowing and small surface fractures or fissures in the shingle.
- **Rainfall** will wash away the granules over time, causing the tile to degrade. Traces of aggregate in the gutter signify potential problems.
- **Wind** can get under the exposed tabs on the shingle and cause them to be ripped from the roof.
- **Hailstones** can easily damage the roof covering, causing small depressions in the shingles, and potentially breaking off weak shingles.



At left: a roof with visible hail damage



At right: Wind has blown off ridge shingles and damaged others.



Above: Shingles overheated by the sun and/or poor ventilation are curling and cracking.



Above: an extreme close-up of a badly weathered fiberglass-based shingle whose fibers are exposed

Impact Damage

- **Trees** cause the most impact damage by their branches being too close to the roof covering and tree limbs falling onto the roof structure.
- **Walking** on the roof can, in some cases, cause damage to the covering, especially if it is already in brittle condition.
- **Masonry** falling on the roof will often damage tiles. It is not uncommon to see damaged shingles directly below the chimney.
- **Moss** is a big problem on badly drained and shady roofs because it retains moisture and its root system will get under the roof shingles. It's fair to say that you will not generally see moss on a good roof, as the roots need to be constantly moist.
- **Leaves** and pine needles on the roof will also promote fast decay of the covering because they retain moisture on the roof. Also, many species produce acids during the decay process, and these can eat into the asphalt.
- **Airborne** pollutants are often found in industrial areas. Acid rain will quickly erode a roof covering.



At left: another example of shingles that have been overheated by the sun and are now curling and cracking



At left: A chimney has collapsed, damaging the shingles.



At right: A mossy roof is trapping moisture on the structure.

Poor Shingle Installation

Here are some of the issues that often occur due to poor installation:

- **repairs** that were improperly carried out;
- **shingles on a low-pitch roof** where the use of shingles was not intended;
- **joints that were not overlapped**, allowing water to drain right onto the sheathing; and
- **improper nailing** that was not done to the manufacturer's specifications, where either the nails are too short, causing nail pops, or not enough nails were used. Every 3-tab shingle should have four fasteners (or six in high-wind areas).



Above: Improper repairs have been made to this shingled roof.



Above: Nail pops indicate where the fasteners have backed out of the roof.

Material Failures

Inspectors will occasionally see failure due to manufacturing defects, such as blistering from within the shingle, or premature cracking of the shingles, particularly with fiberglass-based shingles. One particular brand of shingle was the subject of a class-action lawsuit against Bird Fiberglass Shingles of New Hampshire, which was settled in 2001.



This kind of damage is typically seen on fiberglass-based shingle roofs.

(Courtesy of Inspect-NY)

Ventilation Problems

Many problems with asphalt shingle roofs are caused by poor ventilation of the roof space, which leads to overheating of the roof coverings. This is more apparent when the roof has multiple coverings which can trap additional heat. It is very common to see shingles that are less than 10 years old but are in very bad shape due to overheating caused by poor ventilation, or overheating caused by the presence of too many layers of shingles.

Reporting Requirements

The inspector must report on the following when inspecting asphalt shingle roof coverings:

- shingle type;
- missing shingles;
- damaged shingles;
- number of layers of covering;
- signs of previous repairs;
- shingles that are cupping or buckling;
- moss or vegetation growth on the shingles;
- granular erosion;
- shrinkage of shingles;
- lack of a drip edge;
- nail pops; and
- shingles that have been incorrectly installed.

SLATE TILE ROOFING

The different varieties of solid tile roofs are basically all inspected in the same way and tend to exhibit similar problems that the inspector needs to report on.

In this section, we'll look at most of the solid tile types: slate, clay, concrete, and asbestos-cement. We will also look at their installation, common problems and reportable issues. Remember: Solid tile roofs should not be walked on. They should be inspected either from the eaves using a ladder, or from the ground using binoculars.

Slate Roofs

Slate is a sedimentary rock (which means that it has settled into layers) that is easy to split into tiles. Most slate tiles used in residential construction are 3/16-inch to 1/2-inch thick, but some older tiles are much thicker.

Slate roofs are roughly five times the weight of standard shingle roofs; therefore, the roof framing has to be designed to carry a much greater load than normal. Roofs that have been retrofitted with slate should have been re-engineered to carry this additional load.

Slate has been around as a roof covering in Europe for more than a thousand years. Many churches, castles and manor houses were originally built with this type of roof covering. In many cases, the same tiles are still in situ, although they have probably been refitted many times over the centuries due to leaks or failure of their connectors.

American slate differs in quality, depending on where it was mined. For example:

- Pennsylvania slate is somewhat soft and lasts less than 100 years.
- Vermont slate is denser and lasts well over 100 years.
- Virginia slate is very hard and can last more than 200 years.

The poorest-quality slate can be recognized by ribboning in the color, where a band of a lighter stone can be seen running through the slate. These slates tend to break along this band due to differential weaknesses. Where such slate has been used, the ribboning should not be visible on the exposed face of the tile.

Other rules-of-thumb for slate roof installation:

- Slate roofs should not be installed where the roof pitch is less than a 4/12.
- Slate can be applied over battens, plank or sheet sheathing.
- Slate tiles are generally fastened with two copper nails each.
- Joints between tiles should be staggered by 3 inches per course or row.

In every second row, the joints can line up vertically. There should be a minimum of 2 inches of headlap clearance. That is the point where there are three layers of tile, and there can be as much as 4 inches, depending on the pitch of the roof.

SLATE SHINGLE HEADLAP	
Roof Slope (Pitch)	Minimum Headlap
between 4:12 and 8:12	4 inches
between 8:12 and 20:12	3 inches
over 20:12	2 inches

The most common problem with slate roofs occurs with the fasteners rather than with the tiles themselves. Slate nails should be of copper rather than ferrous metal (iron), as copper will not rust over time and cause the tiles to start slipping.

When inspecting a slate roof, inspectors should report on the following:

- missing tiles;
- broken tiles (though some corner chipping is expected and acceptable);
- tiles that are slipping out of place; and
- signs of previous repairs.



At left: an older slate installation showing many broken and dislodged tiles



At right: a new slate roof; notice the crisp edges on the slate.



At left: an older roof; small chips at the corners of tiles are generally not of concern. Note the ridge cap, which is made of clay tile.

CLAY AND CONCRETE TILES

Concrete and clay tile roofs are very similar from an inspection perspective, as they are all installed in the same way and tend to exhibit the same problems in service.

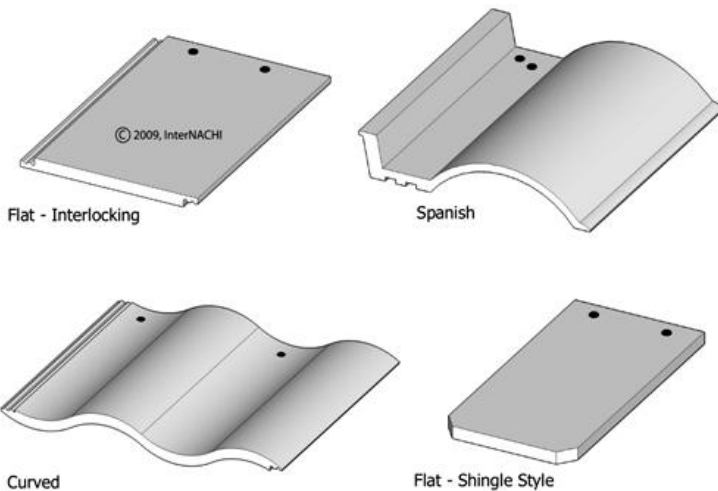

They are both made in similar sizes and shapes, such as flat, curved or corrugated, and may or may not be of an interlocking design. In most cases, tile designs are produced to be installed as ridge caps and used in other specialized locations.

Both clay and concrete tiles have a long lifespan. Problems other than those from mechanical damage tend to be from failure of the underlayment and flashings, rather

than failure of the tiles themselves. In many cases, when the roof needs repair, the original tiles are taken up and stored while the substrate is replaced. The tiles are then re-installed, with the addition of new tiles to replace the damaged ones.

Remember that tiles can be up to five times heavier than asphalt shingles; therefore, the roof system needs to be much heavier to support the additional load.

Clay Tiles

Regardless of style differences, all clay tiles are made from terracotta, the same material that common houseplant pots are made of, and they are damaged just as easily.

Terracotta tiles are produced in molds or extruded from clay with high silicon content which, when fired, changes composition and becomes impervious to water. Clay tiles may also be glazed to add color and a high-gloss finish.

When discussing clay tiles, we tend to think of the Spanish or barrel style of tile, but there are many variations in style, from the corrugated look, to flat and fully interlocking designs.



These are samples of traditional clay tiles, also known as Spanish or barrel-roof tiles.



At left: a flat clay tile roof



At right: a glazed clay tile roof

Concrete Tiles

Concrete tiles are also available in a wide range of designs and finishes. Many of them are designed to look like other materials, such as slate, clay, and even cedar shakes and shingles.

The process of manufacturing concrete tiles is similar to that of manufacturing clay tiles, except concrete tiles don't need to be fired in a kiln. A chemical process converts the concrete from a liquid slurry into a rigid tile.

Some concrete roofing tiles require painting to extend their lifespan. This maintenance should be performed roughly every five years, depending on the local climate.



Above left: These look like traditional Spanish-style clay tiles, but they're actually concrete tiles.

Above center: Another concrete design

Above right: Although it looks like slate, this roof is actually made of concrete tile.

Installation

Both clay and concrete roof tiles are installed in the same manner. They are installed over traditional planking, sheathing, or on some older installations.

Most concrete and clay tile systems rely on their underlayment for complete weather protection, and the lower the pitch of the roof, the more robust that underlayment needs to be. As a general rule:

- a roof pitch lower than 4:12 should have a double underlayment or be applied over a built-up roofing system; and
- a roof pitch lower than 2½:12 should not have tile installed at all.

Some fully interlocking designs of tiles do not require an underlayment, as they are considered to be totally impervious when installed and flashed correctly.

Many designs of both concrete and clay tile roofs require the installation of blocks to correctly position the individual tiles. In the case of traditional Spanish or barrel tiles, these are installed vertically up the roof surface. In other cases, they are required to run horizontally across the roof plane.

All tile roofs should be installed with a minimum of one corrosion-resistant fastener per tile, if the tile weighs less than 9 pounds per square foot. Heavier tiles and those installed in snow-load areas require a minimum of two fasteners.

All open ends of shaped tiles at both the eaves and at any valleys should be sealed to prevent birds and other wildlife from entering the area between the tiles and the underlayment.

Inspection

As previously stated, tile roofs should not be walked on, as they can be very easily damaged by foot traffic. From a ladder at the eaves or from the ground, the inspector should pay particular attention to the following potential issues:

- broken or missing tiles;
- tiles that have moved out of position;
- signs of previous repairs;
- signs of moisture evacuating the roof from under the tiles;
- missing, damaged or rusting flashings; and
- missing or deficient bird and pest barriers.

The inspector should always report on the following:

- the method used to inspect the roof;
- the material and style of the roof covering;
- missing, damaged or slipped tiles;
- missing or damaged flashings and bird stops;
- any signs of moisture penetrating the roof covering; and
- any required re-painting, where applicable.

ASBESTOS CEMENT TILES

Asbestos-fiber cement tiles were a very common roof covering from the 1930s up to the early 1960s. In fact, many homes of that period had both asbestos cement roofs and wall coverings.

The main problem with asbestos tiles is that they are relatively thin and become very brittle over time. This makes them susceptible to mechanical damage, such as tree limbs falling onto the roof and fracturing or breaking the tiles.

These roofs can be particularly costly to repair since it is extremely difficult to find replacement tiles. If the roof covering needs to be removed and replaced, the debris has to be disposed of under U.S. EPA guidelines.

Again, the inspector should never attempt to walk on an asbestos cement tile roof.

The inspector should evaluate the roof system just like any other roof covering material, paying particular attention to:

- missing or broken tiles;
- tiles that have been moved out of position;
- signs of previous repairs; and
- missing or damaged flashings.



Above: diamond-pattern asbestos cement shingles



Above: side-lapped asbestos cement shingles

The inspector should always report on the following:

- the method used to inspect the roof;
- the material and style of the roof covering;
- missing, damaged and slipped tiles;
- signs of previous repairs (tiles siliconed back in place is common); and
- missing and damaged flashings.

WOOD SHINGLES AND SHAKES

Wood shingles and shakes are a popular choice for roof and wall coverings in many parts of the U.S. because of their rustic appeal. However, these aesthetic considerations come at a price, as shake and shingle roofs are far from being maintenance-free or long-lasting.

Generally, wooden shake or shingle roofs should not be walked on. They are easily damaged and can be very slippery when wet or moss-covered.

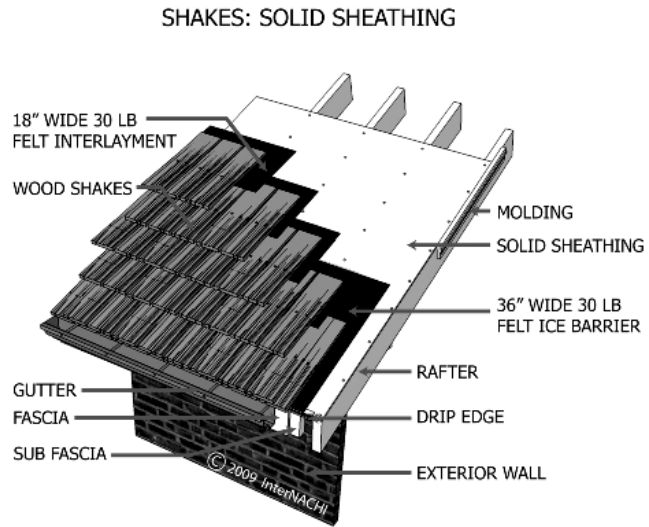

There are different wood species, grain patterns, and lengths of wood shingles and shakes, and such details can be extensive. This manual covers the fundamental points that the inspector must know in order to be able to evaluate most wooden roof coverings.

The Basics

- A **shingle** is machine-cut on both faces and on all sides.
- A **shake** is hand- or machine-split and, therefore, has a less finished look and is less uniform.
- Both shakes and shingles are usually made from cedar, as its natural oils are both a preservative and an insect repellent. Inspectors may also find shingles made of redwood and some types of pine.
- The steeper the roof's pitch, the longer-lasting the roof covering.
- Shingles and shakes are graded with numbers, with 1's being of far higher quality and longevity than 4's.
- The tighter the grain is, the longer it will last, with slow-growth trees providing the best-quality shingles, since the wood is denser.
- When inspecting at the bottom edge of the shake, look carefully at the grain. The direction of the grain through the shingle factors into its ability to resist cupping, bowing and splitting.

Also:

- Vertical-end grain is the best quality and is known as edge grain.
- Angled-end grain is of lesser quality and is known as sash grain.
- Horizontal-end grain, known as flat grain, is of poor quality and will generally fail quickly.

Wood Shingles

As explained, a wood shingle is a machine-sawn wooden tile. Its installation requirements are different from those of a shake. These include the following:

- Shingles are a 3-ply roofing material, meaning that, at any point on the roof's surface, there should be three overlapping shingles.
- A gap of 1/8-inch to 3/8-inch is required between shingles to allow for swelling when they're damp.
- Shingles should be applied over planks or skip sheathing in humid climates, as they need adequate ventilation to prolong their life. They can also be installed over sheet decking in more arid climates, or when installed with a nylon mesh underlayment to promote ventilation.
- Tar paper, or a similar non-permeable grade exposure membrane, should extend up from the eaves a minimum of 3 feet.
- Shingles should be installed over tar paper or a similar underlayment, although this is not always required if installed over skip sheathing.
- Joints between shingles should be offset over three courses, with a minimum overlap of 1-1/2 from one course to the next.
- They should have only two corrosion-resistant fasteners per shingle, not less than 3/4-inch from the edge, and not more than 1 inch above the edge of the next course.

WOOD SHINGLE WEATHER EXPOSURE AND ROOF SLOPE				
WOOD MATERIAL	Shingle Length (in inches)	Grade	Exposure (in inches)	
			3:12 up to 4:12 pitch	above 4:12 pitch
shingles of naturally durable wood	16	# 1	3¾	5
		# 2	3½	4
		# 3	3	3½
	18	# 1	4¼	5½
		# 2	4	4½
		# 3	3½	4
	24	# 1	5¾	7½
		# 2	5½	6½
		# 3	5	5½

Wood Shakes

Shakes are the more rustic-looking wood roof covering and are generally split, not sawn. Their installation is somewhat different from wood shingles.

- Shakes are generally a 2-ply covering, so, at any point on the surface, there are only two layers overlapping.
- Shake roofs rely on an underlayment for weather protection. The shake covering itself is not designed to be impervious.

- Every course requires an interlayment of roofing felt above its exposed area and under the next course.
- They require a gap between shingles of 3/8-inch to 5/8-inch to allow for expansion when damp.
- Shingles should be applied over planks or skip sheathing in humid climates, as they need adequate ventilation to prolong their life. They can also be installed over sheet decking in more arid climates.
- Joints between shakes should be offset over three courses, with a minimum overlap of 1-1/2 from one course to the next.
- They should have two corrosion-resistant fasteners per shake, not less than 3/4-inch in from the edge, and not more than 1 inch above the edge of the next course.
- Shakes should not be installed on a roof that has a pitch of less than 4:12.

WOOD SHAKE WEATHER EXPOSURE AND ROOF SLOPE

WOOD MATERIAL	Shake Length (in inches)	Grade (per Wood Shingle Council)	Exposure (in inches)
			Minimum 4:12 Pitch
shakes of naturally durable wood	18	# 1	7½
	24	# 1	10
preservative-treated taper shakes of southern yellow pine	24	# 1	10
	18	# 2	5½
	24	# 2	7½
taper-sawn shakes of naturally durable wood	18	# 1	7½
	24	# 2	10
	18	# 1	5½
	24	# 2	7½

To read more about shakes and shingles, visit www.cedarbureau.org.

Inspecting Wood Roofs

Although wooden shake and shingle roofs look similar, they have different installation requirements. Still, inspecting both types is basically the same. It's worth repeating that neither shake nor shingle roofs should be walked on.

Inspecting wooden roofs can be problematic, especially since they should not be walked. As with all other roofing systems, shake and shingle roofs fail for similar reasons, such as:

- weathering issues;
- ventilation and rot problems;
- mechanical damage;
- poor installation;
- lack of maintenance; and
- wood-destroying insects and other organisms.

Weathering

Weathering and orientation are the biggest factors affecting the longevity of any wooden roof covering. A badly weathered roof will have a bleached-out appearance, show splitting of the shingles, and cupping, bowing and erosion of the softer parts of the grain on the exposed areas of the shingle. Additionally:

- Rainwater and melting snow will erode the roof covering at a rate of a minimum of 1/64-inch per year.
- Sunlight, through ultraviolet radiation, breaks down the cell structure of the timber. It also dries out the oils and resins in the wood. This, coupled with the expansion and contraction of the shingles through heating and cooling, shortens the life expectancy of this type of roof covering.
- Orientation is also a factor. Typically, south-facing roof planes will weather more quickly than north-facing ones.
- Wind will also damage shake and shingle roofs, especially if they are already somewhat dried out and brittle.

Ventilation

Many wooden roof systems fail prematurely due to inadequate ventilation, forcing them to store moisture, which promotes rot. The inspector should always check for dark-looking patches on the roof surface that may indicate permanently damp areas of the roof covering. If possible, the inspector should probe these areas if s/he can reach them to see if the roof covering is soft in these areas.

Mechanical Damage

Like all other roof systems, shakes and shingles are easily damaged by:

- overhanging branches;
- hailstorms;
- foot traffic; and
- attacks by golf balls.

SHAKES: SPACED SHEATHING

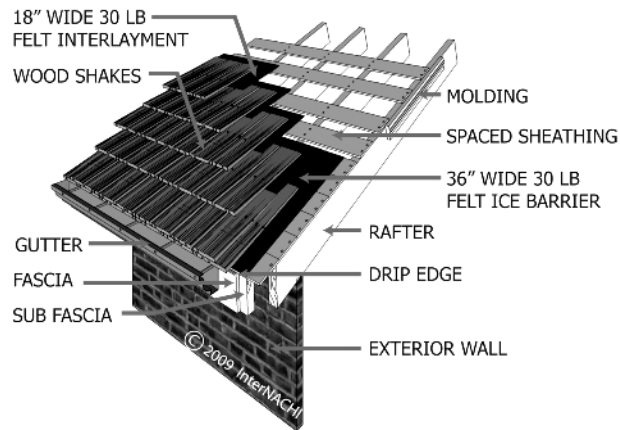

Poor Installation and Repairs

Installation problems are common and include:

- under- or over-driven nails;
- nails too close to the edges;
- buckling of shingles due to being nailed too closely to each other;
- too much shingle exposure (and not enough overlap);
- gaps between subsequent courses lining up;
- lack of proper underlayment or interlayment; and
- improper or missing flashings.

Maintenance Issues

More than any other roofing type, wooden roofs require regular maintenance, as wood itself is an organic material. Any defects can lead to rapid deterioration of the roofing structure. Inspectors should be particularly aware of any vegetation that is trapping moisture on the roof. The inspector may also ask the homeowner/seller how old the roof covering is, and also whether it has received any treatments to seal the surface or repel moss and mildew.

Wood-Destroying Insects and Organisms

Like any other wooden component used in construction, shingles and shakes are susceptible to both wood-boring insects and wood rot. This can be very difficult to spot from a ladder, so it's important to inspect as much of the roof as possible.

Pay particular attention to any roofs that are covered in moss or mildew, as this is a sure sign of dampness in the covering, which will lead to rot very quickly. Chemical treatments are available that will kill moss and mildew.



At left: This is a damp shingle roof already showing signs of rot in places.

(Photo courtesy of Pat Dacey)



*Above: evidence of boring-insect damage to this shake ridge
(Courtesy of Kevin Wattenbarger)*



*Above: shingle ridge detail showing broken shingles and considerable erosion; also note the open W-valley flashing.
(Courtesy of Pat Dacey)*



Above: This is an example of the bottom of the shingle/shake market: untreated pine shingles, complete with knot holes. Notice all the splits. This roof will need replacement.



*Above: This is typical erosion of a shake/shingle roof. Even if it has no other defects, this roof is at the end of its lifespan.
(Courtesy of Pat Dacey)*

The MUST-report list includes:

- type of covering;
- method used to inspect the covering;
- location and number of missing or damaged shingles or shakes;
- signs of previous repairs;
- evidence of mechanical damage;
- buckling or cupping of shingles or shakes;
- any signs of damp or moisture on the roof;
- moss or mildew buildup;
- any rotten shingles that can be viewed or probed; and
- rotten or missing flashings.

Again, the inspector should never comment on the future lifespan of a wood roof. There are just too many variables that need to be taken into account, so it is impossible to be accurate, and this is outside the scope of a home roof inspection. Remember that a roof that appears to be in good shape because the current owners maintain it can very quickly deteriorate if the next owner fails to follow the same kind of maintenance schedule.

QUIZ 4

1. **Asphalt shingles use either _____ or _____ as a base.**
 - fiberglass....carbon fiber
 - cellulose....fiberglass
 - cellulose....polyvinyl chloride

2. **Asphalt shingles that are made up of several layers are called _____.**
 - 3-tab
 - engineered
 - architectural

3. **T/F: An underlayment is required under all asphalt shingles.**
 - True
 - False

4. **When installed according to the manufacturer's instructions, asphalt shingles can be installed on a roof that has a pitch as low as _____.**
 - 2:12
 - 3:12
 - 4:12

5. **T/F: Tree branches overhanging the structure should be noted because of their potential for damage to the roof covering.**
 - True
 - False

6. **Small dimples or circular depressions on asphalt shingles are often caused by _____.**
 - hailstones
 - nail pops
 - under-driven nails

(continued)

7. **T/F: It is not necessary to note previous shingle repair if the repair was performed by a professional.**

- True
- False

8. **Most jurisdictions allow no more than _____ layers of asphalt shingles.**

- two
- three
- four

9. **T/F: Slate tile roofs should never be walked on.**

- True
- False

10. **The lowest quality of slate tile has _____.**

- ribboning in it
- feathered edges
- a dark grey color

11. **T/F: Clay tiles are easily distinguishable from concrete tiles.**

- True
- False

12. **T/F: Most concrete and clay tiles are installed the same way.**

- True
- False

13. **T/F: InterNACHI's Standards of Practice require that all clay and concrete tile roofs be walked on.**

- True
- False

(continued)

14. Concrete and clay tile roofs with a pitch of less than 4:12 require _____ layers of underlayment.
- two
 - three
 - four
15. T/F: Solid tile roofs should not be installed over solid sheathing.
- True
 - False
16. Fasteners made of _____ are recommended for tile roofs.
- stainless steel or iron
 - copper or stainless steel
 - galvanized steel or iron
17. The enclosure at the eaves' edge of a traditional barrel-style roof is called a _____.
- soffit vent
 - bird stop
 - drip edge
18. Asbestos cement roof shingles were commonly installed between the _____.
- 1930s and 1960s
 - 1860s and 1930s
 - 1960s and 1990s
19. When reporting on an asbestos cement tile roof, the inspector should _____.
- recommend immediate replacement
 - note the roof material
 - walk the roof looking for broken tiles

(continued)

20. A wood shingle is _____-cut, whereas a shake is split by _____.

- machine.... hand
- hand.... machine
- machine.... saw

Answer Key is on the next page.



Answer Key to Quiz 4

1. Asphalt shingles use either cellulose or fiberglass as a base.
2. Asphalt shingles that are made up of several layers are called architectural.
3. T/F: An underlayment is required under all asphalt shingles. *Answer: True*
4. When installed according to the manufacturer's instructions, asphalt shingles can be installed on a roof with a pitch as low as 2:12.
5. T/F: Tree branches overhanging the structure should be noted because of their potential for damage to the roof covering. *Answer: True*
6. Small dimples or circular depressions on asphalt shingles are often caused by hailstones.
7. T/F: It is not necessary to note previous shingle repair if the repair was performed by a professional. *Answer: False*
8. Most jurisdictions allow no more than two layers of asphalt shingles.
9. T/F: Slate tile roofs should never be walked on. *Answer: True*
10. The lowest quality of slate tile has ribboning in it.
11. T/F: Clay tiles are easily distinguishable from concrete tiles. *Answer: False*
12. T/F: Most concrete and clay tiles are installed the same way. *Answer: True*
13. T/F: InterNACHI's Standards of Practice require that all clay and concrete tile roofs be walked on. *Answer: False*
14. Concrete and clay tile roofs with a pitch of less than 4:12 require two layers of underlayment.
15. T/F: Solid tile roofs should not be installed over solid sheathing. *Answer: False*
16. Fasteners made of copper or stainless steel are recommended for tile roofs.
17. The enclosure at the eaves' edge of a traditional barrel-style roof is called a bird stop.
18. Asbestos cement roof shingles were commonly installed between the 1930s and 1960s.
19. When reporting on an asbestos cement tile roof, the inspector should note the roof material.
20. A wood shingle is machine-cut, whereas a shake is split by hand.

FLAT ROOFS: ROLL ROOFING

Roll roofing is common on low-pitch residential roofs, particularly those on shed-roof additions to existing structures. In many cases, these have been installed by the homeowner with insufficient regard for the manufacturer's installation guidelines.

The general rule of thumb with these roofs is that the more plies they have, the longer they are going to last, but none of them has a very long lifespan.

All roll roofing is 36 inches wide and is manufactured similarly to asphalt shingles. The base material is felt impregnated with asphalt or bitumen, making it impervious to moisture. The areas designed for full exposure also feature a granular mineral topcoat, which is provided to protect the roofing from the effects of ultraviolet radiation. In some areas, the topcoat has a reflective surface to stop the roof's surface from overheating, which breaks down the asphalt or bitumen. There are two methods of attachment to the roof surface: nailed down with all nail heads covered, or "torched down," where the sheet is heated with a propane torch to melt the asphalt down onto the roof surface.

Many roll roofs have insufficient pitch to properly shed water, and these tend to exhibit signs of ponding on the surface. In dry weather, it is often possible to observe a ring of dirt on the roof's surface where the pond was until the water evaporated.

Single-Ply Roll Roofing

As the name suggests, this type of roof has only one layer of covering except where the sheets overlap. They typically have a 3-inch lap which has no mineral granules, so the rows or courses on the roof will appear to be 30 to 33 inches apart.

This covering should be installed by working up from the roof's eaves. The top edge should be nailed every 3 to 4 inches, in accordance with the manufacturer's instructions. The next roll should be adhered over the lap with roofing cement so that no nail heads are visible. Any exposed nail heads should be sealed with roofing tar.

These coverings typically last for only five to 10 years. They tend to last better if they are fully adhered to the roof sheathing, rather than just at the laps.

Double-Ply Roll Roofing

This covering has two layers at any point on the roof. This can be achieved by a double application of a single-ply material (as discussed above), with the joints between rows offset by half of the roll width. Wide selvage roofing is a type of roll roofing whose bottom half has mineral granules on the surface, so each row has a full 50% lap over the lower courses. Therefore, each course on the roof would appear to be 18 inches wide. Again, this will tend to last better if the whole roll is fully adhered to the roof decking.

Despite the double covering, and even when fully adhered to the roof decking, these roofs still have a lifespan of only 10 to 15 years.

Inspecting Ply Roofs

The inspector should pay particular attention to the following:

- any tears or rips of the covering;
- any signs of the lap edges lifting;
- exposed nail heads;
- blisters under the roof covering;
- loss of the granular covering; and
- signs of ponding on the roof.



*Above left: a poor, non-professional installation of roll roofing
(Courtesy of Richard Moore)*



Above right: The edge of this single-ply roof is lifting.

At right: This is roll roofing that is not supported along a joint and has sunk into



Reportable issues with roll roofing include:

- the type of roofing material;
- the number of plies, if it can be determined;
- the method of inspection;
- any rips or tears in the material;
- lifted edges;
- exposed nail heads;
- loss of granules;
- blistering; and
- signs of ponding.

FLAT ROOFS: BUILT-UP ROOFING

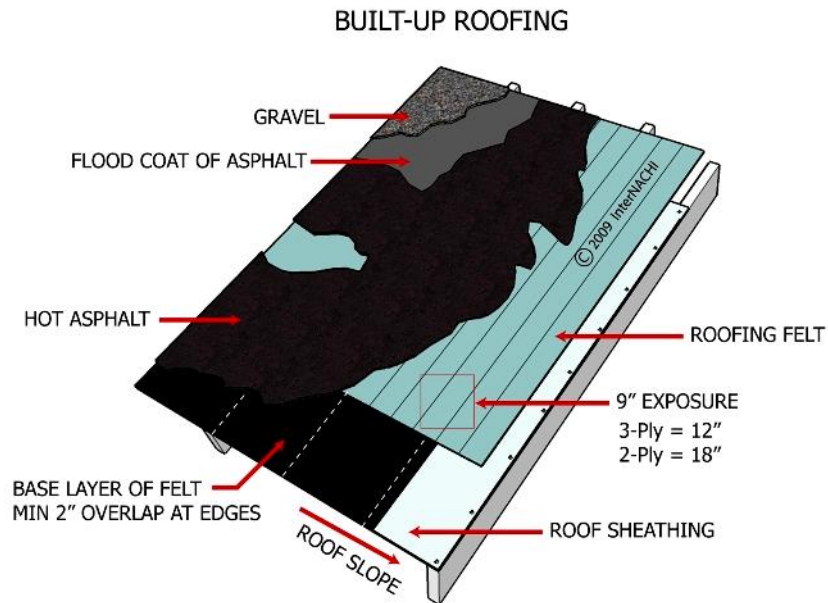

Traditional built-up roofing is abbreviated BUR and is also sometimes called tar-and-gravel roofing. This is the logical extension of roll roofing concepts. While no longer used in new residential construction, most inspectors will run into it at some point on older, flat roof systems or, more commonly, on apartment and commercial buildings.

As with roll roofing, the more plies or overlapping layers there are, the longer the roof will tend to last. Built-up roofing is also not maintenance-free. It needs a periodic application of an additional topcoat of tar or bitumen, or a supplementation of the ballast or granules.

Built-up or tar-and-gravel roofs should not be installed on a roof with a pitch of more than 3:12, as the asphalt and ballast will migrate down the roof, especially in warmer climates. However, it's rare to see BUR on anything other than a flat roof.

Installation

Similar to roll roofing, layers or plies of asphalt or tar-impregnated roofing felt are applied to the roof decking or sheathing. A built-up roof may have as few as two plies, but four or five are more common.

Each layer is hot-mopped down. The heated asphalt or modified bitumen is applied not only to the roof decking, but also between each ply or layer of the covering, and as a continuous top or flood coat over the entire roof surface.

The final finish may be plain asphalt, mineral granule-impregnated roll roofing (again, hot-mopped in place), or separately applied mineral granules or crushed stone or slag, known as ballast.

These roof systems also typically feature parapet designs, with the BUR extending up the sides of these small surrounding walls or other interfaces between planes on the roof's surface.

Internal drains are common on these roofs and, if installed, the parapet walls should also feature scuppers, which are auxiliary or overflow drains which allow excess water to flow off the roof in case of a blockage in the normal drain system.

Inspection

If the roof has been installed with a stone-ballast covering, you will not be able to see the roof surface and should report that the covering is not visible.

These are the main areas of concern when inspecting built-up roofs:

Alligatoring is the term for small cracks or fissures that appear in the surface over time. As the asphalt dries out, it loses its flexibility and cracks due to thermal expansion and contraction. This can allow moisture to saturate the felt layers and, over time, causes the roof to leak.

Blistering, as the name suggests, refers to large blisters that form on the roof surface, indicating trapped moisture between the plies. These will cause the roof to delaminate, reducing its life expectancy. Some roofers will cut the blister off and dry the roof out before repairing the area, but that's the roofer's call, not yours. It is beyond the inspector's job to comment on whether the system is repairable or not.

Mineral loss occurs on roofs that have a topcoat of granular finish, or where ballast has been applied. The finish should be uniform. Any areas that have worn away by either mechanical damage or erosion will fail quicker than areas where the surface finish is intact.

Even in dry weather, it is possible to see evidence of **ponding** or standing water that has subsequently evaporated. Many roofs have simply settled over the years and no longer slope properly toward the drains or gutters. Sometimes, this sinkage has been caused by too many layers of roof covering, where the old surface should have been removed prior to a new application.

This can be quite expensive to correct because either the roof sheathing has to be rebuilt, or additional drains need to be tied in to the water runoff system. Roof drains and scuppers should also be examined, and any blockages noted.

Cracking at roof wall interfaces or other flashed areas, where differential movement between the roof covering and a wall system has actually caused a full separation of the BUR, is another defect. In these cases, inspectors may see significant water damage on the interior of the building. However, BUR systems are known for not leaking directly under visible damage. Since the roof is a ply system, water often migrates horizontally under the plies before finding another weak area and migrating downward.

The inspector should report any of the following:

- type of material, and whether it is ballasted or not;
- how it was inspected;
- cracks or alligating;
- mineral loss (if applicable);
- evidence of ponding; and
- blocked drains or scuppers.

At right: an example of alligating of the roof's surface covering



At left: This is a blister in an asphalt roof caused by heat build-up in a void.

At right: This photo shows de-lamination of the plys over a roof joint, and loss of aggregate in this area.



FLAT ROOFS: MEMBRANE

As roofing manufacturers have worked to develop more durable roofing materials, they have looked to various plastics and synthetic rubber. Membrane roofing systems use rubber and plastic-based, single-ply roofing materials. Most home inspectors will not see these types except, perhaps, on trailers. They are typically used on apartment buildings, condos, and in commercial applications.

The term "membrane roof" applies to many different material types and installation methods.

Some systems come in sheet form, with sheets glued or chemically bonded together. Others are sprayed on as a self-setting polymer or as an expanding foam.

The earliest of these systems used PVC sheets (polyvinyl chloride) that were glued or taped together. These had a reputation for failing rapidly from ultraviolet radiation, and also from shrinkage that pulled the roof covering away from the outer edges of the roof. Inspectors may also see problems where joints or tapes have separated, along with problems with wrinkles in the covering. In some cases, it is possible to see ruptures in the roof covering where the forces exerted by the covering itself have torn the membrane.

When evaluating a building that has a membrane roof, the inspector should defer any report on the roof's condition to a licensed commercial roofing contractor.

Mobile Homes and Membrane Roofs

It is quite likely that inspectors looking at mobile or manufactured homes will come across rubber membrane roofs. Inspectors are advised against attempting to walk on these surfaces, as old rubber membranes tend to get very brittle and are easily damaged. Any prior failures of the roof covering will have turned the sheathing into something with the tensile strength of wet cardboard.

Inspect from a ladder, and report on:

- tears or cracking in the surface;
- deficient flashings around the vents;
- signs of ponding;
- ripples in the roof covering; and
- signs of the covering shrinking and pulling away from the sides of the roof.



At right: This is an EPDM membrane covering. The ponding should be reported.

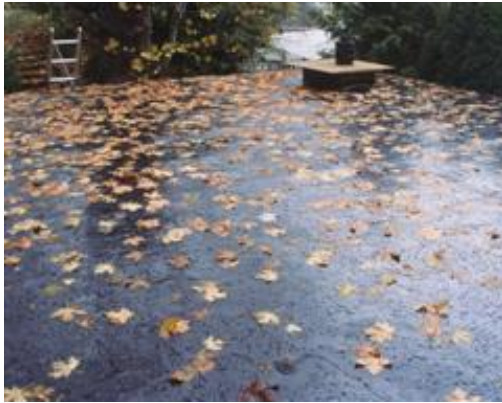

Above: This is a standard rubber membrane roof on a commercial property.



Above: This is another EPDM membrane. Notice the wrinkles between the sheets. This could easily allow water penetration. These areas need full evaluation.

METAL ROOFING

Metal Roofs: Sheet and Tiles

Until fairly recently, it appeared that metal roofs had gone out of style. In the U.S., they have been associated with run-down rural properties.

Contrary to their aesthetic reputation, metal roofs are sturdy and long-lasting, when properly maintained, and modern paints and powder coatings make them nearly maintenance-free. In the northeast, metal roofs are making a comeback because of their superior ability to shed snow loads quickly. They are also free of the ice-damming problems associated with shingles and tiles.

Metal roof components are manufactured from steel, galvanized steel (zinc-coated steel), copper, lead, aluminum, and terne (a tin-lead alloy-coated steel). Tin-plated stainless steel is available for locations where regular steel would not last too well, such as salt-air coastal regions.

Metal Shingles

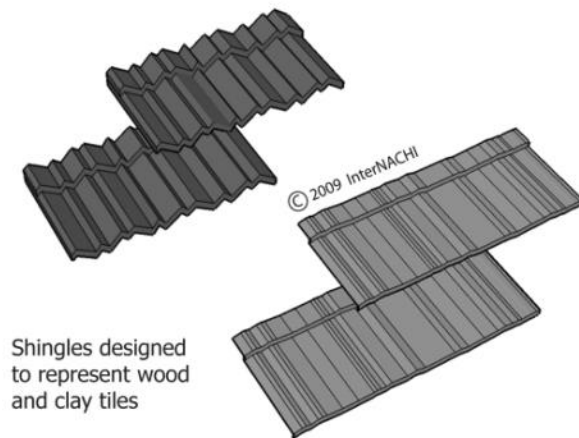

Materials

Steel, either galvanized, painted or both, has been used in sheet form with standing seams, corrugated or in tile format.

Tin is now used primarily as a coating on steel or in an alloy. At one time, pure tin was common both as tiles and as sheet material.

Copper has long been the choice for high-end metal roofs because of its long lifespan. Normally, it is used as standing-seam roofing, but it can also be soldered together (as was the case in the past).

Aluminum is not very common as a residential roofing material, although some shingles of this material are designed to look like wood shakes. It is used extensively in commercial applications where its low weight is a design advantage on wide-span roofs. Aluminum sheet roofing is easy to spot, since it comes in small lengths and has to be installed using rubber gasketed screws through the surface and into the roof decking.

Terne is the same as steel or galvanized steel, and is sometimes used to manufacture both sheet and tile roof coverings.

Lead is not commonly used in North America as anything other than a flashing material. In Europe, however, it was used extensively in sheet form on smaller flat roofs, particularly those with parapet walls and internal drainpipes, because the material is malleable and easy to solder together.

Styles and Installation

Tiles are coming back into fashion. They were common from the early 1900s and still in use until the 1930s. Manufacturers produced unusual designs, aping slate and terracotta. Some used very ornate features, and designs with scalloped edges and diamond shapes were not unusual. All metal tiles have a pressed or embossed design which not only increases their rigidity, but also adds texture to the tile. They sometimes have a granular coating, but most are just painted.

Metal tile roofs were originally installed over plank sheathing and a layer of tar paper, and then fixed to the roof with regular roofing nails. Some designs were also fully interlocking to prevent moisture intrusion.

Modern metal tile roofs can be installed over regular sheet ply or OSB sheathing, with an underlayment of roofing felt. Today's tiles are fully interlocking to provide better weather protection and resist being torn up by high winds.

Standing seam is the product that first comes to mind when discussing metal roofs. Its distinctive ridges serve two purposes: the seams connect one section to the next, and they also hide the bracket that connects the lengths of steel roofing to the decking. Flat-seam roofs generally follow the same pattern but are less pronounced.

Most modern systems are manufactured on site from rolls of coated steel or copper. The rolls are 20 to 24 inches wide and typically come in 50-foot lengths. The metal is cut to length and then fed through a forming machine that folds up the two outside edges to form a pan (normally, 1¼ inches high, and the other 1½ inches high when butted together). The extra 1/4-inch is folded over the adjacent flange, and then both are folded over again, with the clip holding the material to the decking sandwiched in the middle.

Some older copper roofs have over-locking standing or flat seam, and were also soldered together where the plane of the roof was too long to be spanned by a single sheet.

Older sheet-metal systems came in only 8-foot lengths, so inspectors will sometimes see an over-locked or flat seam joint part of the way down the roof plane.

All metal roofs can be installed over plank or sheet roof sheathing, but they should all be installed with a tar paper or roofing felt underlayment. Also, since metal systems do not breathe well, the roof ventilation needs to be sound in order to cope with moisture issues. This tends to be less of an issue on older homes, but modern homes with metal roofs need to have properly designed ventilation.

Many older homes were fitted with **corrugated sheet metal** roofing, usually made of steel, galvanized or terne. Although some find it aesthetically displeasing, it is used all over the United States, which speaks volumes for its longevity. It was normally installed over plank sheathing with a layer of tar paper underneath, with the sheets overlapping by one corrugation, and with sheets above overlapping those below.

In most cases, the installation and flashing of metal roof systems is just like clay or concrete tiles.



Above: This is an unusual roof these days, with copper sheets soldered together on the surface. Also, note the soldered-in-place valley flashing.



Above: This is also a metal roof -- in this case, designed to look like Spanish tile.



At left, At an installer is crimping together the seams on a metal roof.

Inspecting Metal Roofs

The major areas to observe when inspecting a metal roof are:

- mechanical damage from branches or other impact;
- rust, in the case of steel or coated roofs;
- signs of repairs;
- splitting along seams;
- galvanic reactions between dissimilar metals (for example, aluminum vents are a bad match for steel roofs);
- paint peeling from the surface; and
- damaged, rotten or missing flashings.



Above: This photo shows a standard corrugated steel roof (top-fixed). The panels have lifted, probably due to wind uplift and poor fastening.



Above: This is an aluminum tile roof showing severe wind damage.

Below: This is a metal tile roof designed to look like concrete tile. The nail in the face should not be there. (Courtesy of Russel Ray)



Below: This a commercial metal roof showing the result of condensate from an HVAC system acting on the roof.



What to report for metal roofing:

- the material and style of the roofing;
- how it was inspected;
- missing and damaged components;
- splitting seams;
- loose tiles;
- signs of rusting;
- painted finishes in poor condition;
- signs of previous repairs; and
- flashing issues.

ROOFING ODDITIES

Although this section is intended as light relief, some of these systems are more common than inspectors may realize.

Plastic Corrugated Roofing

Nearly everyone has seen this material installed over a carport or homeowner-built lean-to. Obviously, any attempt to walk this type of roof is extremely unsafe.



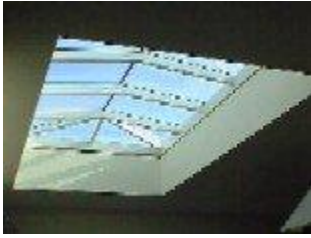

Glazed Roofs

Many modern properties have big areas of the roof that are fully glazed, usually as a feature of an architect's "dream home." However, common problems include leaks and difficulty keeping them clean enough to allow adequate light to pass through.

Plastic Tile Roofs

These are rare. One style has a fully interlocking design over sheet sheathing. It is a very tight system, so ridge and soffit vents should be installed to provide adequate ventilation.



Thatched Roofs

Even in wet climates, and especially in Great Britain and other areas of northern Europe, thatched roofs have been used for centuries. A popular misconception is that they are made from grasses when, in fact, river reeds are the most common material used because they are more rot-resistant.

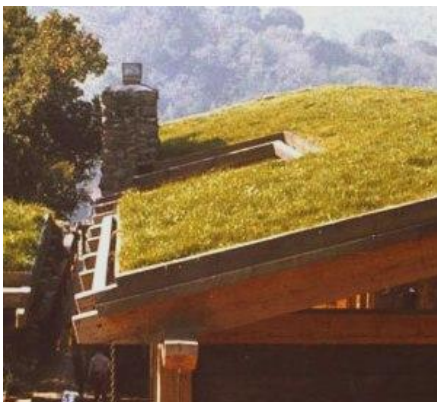

Grass Roof Coverings

There is a strong movement toward green building, and live turf coverings are believed to be both sustainable and energy-efficient.

It goes without saying that the roof needs a very good membrane under the covering, as well as a landscaper with a sense of humor!

QUIZ 5

1. **Standard roll roofing is ____ inches wide.**
 - 24
 - 36
 - 48

2. **The layers that make up a built-up roof are called _____.**
 - plys
 - layers
 - overlaps

3. **Two-ply roll roofing is also called _____ roofing.**
 - wide-selvage
 - built-up
 - tar-and-gravel

4. **The following should be reported when inspecting ply roofing:**
 - splits
 - exposed nails
 - blisters
 - all of these

5. **Built-up roofing is also known as _____ roofing.**
 - asphalt-and-stone
 - tar-and-gravel
 - asphalt-and-rock

6. **Blisters in built-up roofing are caused by _____.**
 - water or air expanding below the covering
 - movement of the building
 - inadequate nailing

(continued)

7. **T/F: Alligatoring of a roof covering is only a cosmetic issue.**

- True
- False

8. **Water stains on a flat roof are signs of previous _____.**

- pooling
- repairs
- ponding

9. **A metal roof covering with "ribs" down it is called _____.**

- standing seam
- edge-lip roofing
- terne roofing

10. **T/F: Metal tile roofs should have exposed nails.**

- True
- False

11. **Sheet copper roofs are jointed with _____.**

- solder or roofing adhesive
- standing seams or solder
- standing seams or flashings

12. **A steel roof and an aluminum vent are a bad match because of _____.**

- the wrong fasteners
- acids in the air
- galvanic reaction

13. **T/F: Metal tile roofs require no underlayment.**

- True
- False

(continued)

14. Metal roof tiles are typically made of _____.

- aluminum
- copper
- steel

15. Crushed stone or gravel ballast on a built-up roof _____.

- never needs replacing
- protects the roof from sunlight
- keeps the roof weighted down

Answer Key to Quiz 5

1. Standard roll roofing is 36 inches wide.
2. The layers that make up a built-up roof are called plys.
3. Two-ply roll roofing is also called wide-selvage roofing.
4. The following should be reported when inspecting ply roofing:
Answer: all of these
5. Built-up roofing is also known as tar-and-gravel roofing.
6. Blisters in built-up roofing are caused by water or air expanding below the covering.
7. T/F: Alligating of a roof covering is only a cosmetic issue.
Answer: False
8. Water stains on a flat roof are signs of previous ponding.
9. A metal roof covering with "ribs" down it is called standing seam.
10. T/F: Metal tile roofs should have exposed nails.
Answer: False
11. Sheet copper roofs are jointed with standing seams or solder.
12. A steel roof and an aluminum vent are a bad match because of galvanic reaction.
13. T/F: Metal tile roofs require no underlayment.
Answer: False
14. Metal roof tiles are typically made of steel.
15. Crushed stone or gravel ballast on a built-up roof protects the roof from sunlight.

ROOF FLASHINGS

EDGE AND RIDGE FLASHINGS

Roof flashings are at least as important as the roof covering itself. A covering can be brand new, but unless the flashings are in a similar condition and properly installed, the roof is going to leak.

Basically, any interface between a roof plane and any other component, including another roof plane with a similar covering, needs a flashing. If it is missing or incorrectly installed, or has already failed, there will likely be problems with the whole roofing system. Complicating matters is the fact that it's impossible to see most flashings.

The only thing better than one flashing is two flashings doing the same job, which is where counter-flashings come into the picture.

Materials

Flashing should be made from corrosion-resistant metal, the most common metals for this use being galvanized steel, copper, aluminum, lead and stainless steel.

Aluminum should not be used in coastal areas, as the salt air rapidly corrodes any flashings made of out this material.

The main types of flashing include:

- edge flashings;
- ridge and hip caps;
- valley flashings;
- roof-wall flashings;
- roof-roof flashings;
- chimney and vent flashings; and
- skylights.

Drip Edge Shapes

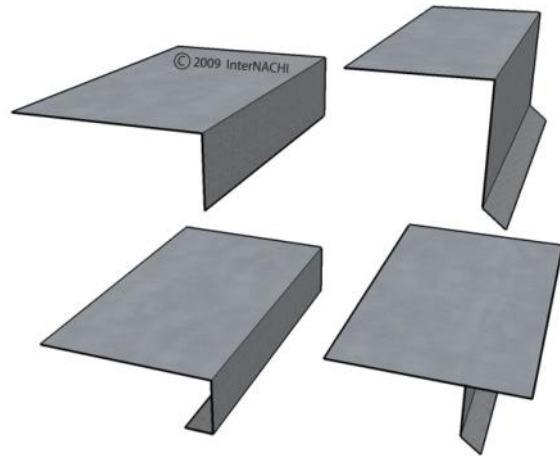

Edge Flashing

All eaves and rake edges need a flashing. These prevent rainwater from wicking into the roof sheathing or decking as it leaves the roof covering. The profile of this flashing ensures that any drips from the edge fall away from the roof sheathing. It is for this reason that edge flashings are also commonly referred to as **drip edges** or **drip flashings**.

In most roofing applications, the drip edge flashing should be installed under the moisture barrier, if fitted on the eaves' edge, and above the moisture barrier on the rake edge.

Many asphalt shingle roofs have a second drip edge installed with a second roof covering, making it hard to see how many layers of shingles there really are. It is worth getting up on a ladder at the eaves to look carefully for a second flashing under the top one.

Ridge and Hip Flashing

In most cases, the ridge or hip flashing is made of the same material as the rest of the roof covering, and is also often referred to as **ridge** or **hip caps**.

On **asphalt shingle** roofs, ridge flashings are made by cutting down standard 3-tab shingles, or they can be bought as a special shingle. In the case of architectural styles, the special shingles fit better and are more effective. Architectural shingles are often cut down and installed over ridge vent systems that not only look unattractive, but have cracks at the peak due to being bent over the ridge. Asphalt shingle caps should extend 4 inches down from the roof peak on both sides.

Ridge caps on **slate tile** are normally made from a terracotta material which is glazed to match the slate color, and then mortared in place. Some of these also feature very ornate designs. Several slate roofs use metal ridge flashing of either copper or lead.

Asbestos cement roofs universally used specially molded roof cap tiles that are fitted right over the peak, and are overlaid in the same manner as asphalt tile to hide the nail heads.

Clay and concrete tiles usually feature specially manufactured ridge caps and ends that are either nailed or mortared in place. It is common to see damaged tile and cracked mortar with these systems.

There are three types of ridge caps for **wood shake and shingle roofs**. The first type is a special ridge cap produced by manufacturers that are actually two thick shingles connected together. The second type is a ridge cap which is formed on site by trimming down standard shingles and shakes, and side-jointing them at the peak with alternating side-lap joints. The third method is to butt together two cedar planks (generally, 1x6 timber).

In all cases, there should be a metal or heavy roofing felt under the cap extending below the uppermost course of shingles or shakes.

The two different **metal roof** styles generally have different ridge caps or flashings. Sheet-metal roofs tend to be installed with ridge caps of the same material and color. Metal tile roofs generally have a ridge system that mirrors the style of the roof itself. All must be installed in line with the manufacturer's instructions.

VALLEY FLASHINGS

Valleys are weak spots in roofing systems. They have a lesser slope than the adjacent roof planes. They erode faster because water is directed into them. Inspectors must look not only at visible flashing, but also at the adjacent roof covering, at least a couple of feet on either side.

Valleys are defined as two main types: open and closed.

Open valleys are defined as roof plane coverings that do not overlap each other across the valley center so that the flashing material is visible, as is the case with most tiles and wood shingles.

Closed valleys are flashings that are not readily visible because the roof plane material is carried over from one plane to the next, as is the case with most asphalt shingle applications.

Valley Flashing Materials

Valley flashing can be made of different materials and designs, depending on the type of roof covering. The common materials include:

- roofing felt or tar paper;
- roll roofing;
- membrane material (ice and water shield); and
- metal flashing, generally galvanized or coated steel, or stainless steel, lead or copper.

Asphalt Shingle Valleys

Open valleys are a rare sight on asphalt shingle roofs and should be formed with:

- **roll roofing** in two layers. The first layer should be 18 inches wide laid face down in the valley, and the second layer should be 36 inches wide laid face up. Both plies should be cemented down, and the shingles cut back to 3 inches from the centerline; and
- **metal flashing** a minimum of 24 inches wide with a center rib at least 1 inch high, nailed at 18 inches on center, and not more than 1 inch from the outer edges. Ideally, this would also have a layer of ice and water shield installed under the flashing, extending the flashing protection to 18 inches on either side of the valley.

In both cases, it is good practice to also cut an angle on the top of the shingle to help stop water from migrating across the top of the shingle.

Closed and closed-cut valleys are more common with asphalt shingle roofs.

A fully closed valley is when the shingles from both planes are interwoven across the valley and extend a minimum of 12 inches onto the adjacent plane.

A closed-cut valley is when the shingles from one roof plane cross over to the next, but the covering overlaid from the other plane is cut back 2 inches from the centerline of the valley.

In both cases, the valleys should still have additional protection with one of the following applied, in addition to the normal felt or tar paper underlayment:

- one layer of 36-inch roofing felt or tar paper;
- one layer of 36-inch roll roofing; or
- one layer of 36-inch ice and water shield.

The shingles should not be nailed within 6 inches of the valley centerline, and the un-nailed areas should be cemented down.

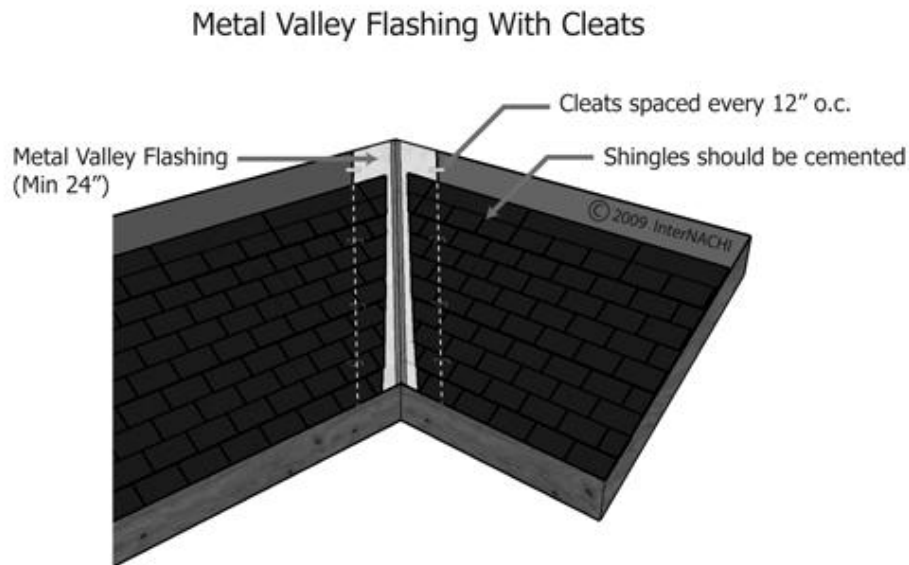

Above: a metal open valley on a poor-condition wood shingle roof

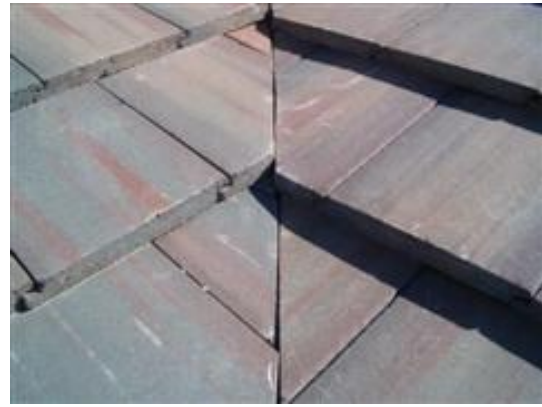

Above: This is a valley on a cement tile roof. Notice how close together the planes are. They should be 1-1/2 inches from the centerline of the valley. (Courtesy of J. Pope)

FLAT ROOF JUNCTION WITH PITCHED SLOPE

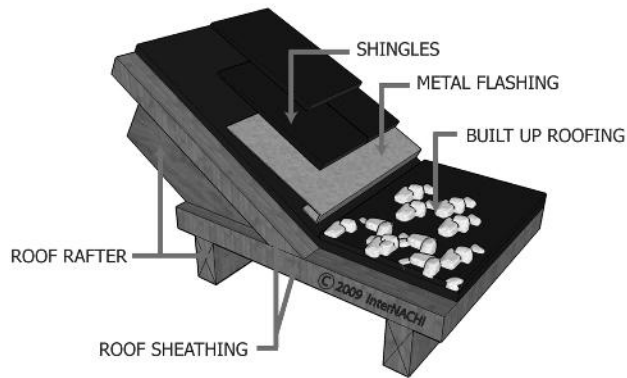

FLAT ROOF JUNCTION WITH PITCHED SLOPE

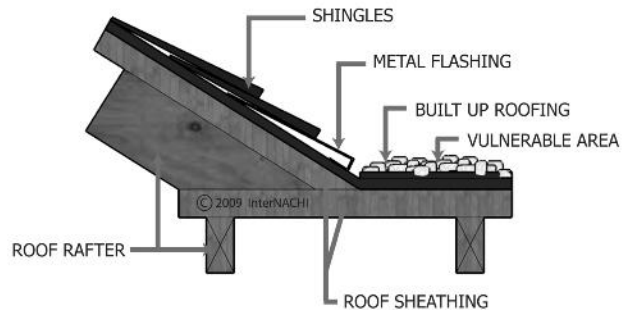

ROOF-TO-ROOF FLASHINGS

One area of the roof often overlooked is the junction where two roofs of different pitch meet each other. Like any other interface, this requires flashing.

It is common to see changes in roof pitch, especially where the house has an addition and the roof plane transitions from a conventional pitch to a low pitch. In many cases, two roof planes are covered with different styles of roof covering. For example, regular shingles on a steep pitch will transition to roll roofing on a flat roof.

In most cases, the material of the lower-pitch roof should be extended at least 12 inches up under the covering of the conventional-pitch roof. In some areas, particularly those with high snow loads, it is better if the lower-pitch covering is extended as much as 3 feet up the conventional plane.

Even in cases where the same roofing material is continued down both planes, there should be additional protection underneath the roof covering at the junction. At a minimum, an inspector should see an extra layer of roofing felt or an impermeable membrane.



The photo at left shows both poor flashing between surfaces and improper use of 3-tab shingles on the lower roof.



Above: another example of poor flashing between surfaces and improper use of 3-tab shingles on the lower roof



Above: another classic DIY flashing

ROOF-TO-WALL FLASHINGS

The design of these flashings is dependent on whether the roof surface is horizontal or inclined down the wall. It also varies based on the type of roof covering and the material that the wall structure is covered with.

The Basics:

All roof-wall interfaces should be protected with two flashings:

- **base flashing**, to prevent moisture from entering the roof-wall structure at the interface of the two; and
- **counter-flashing**, to prevent water that's running down the wall from getting behind the base flashing.

Masonry Sidewall Roof Flashing

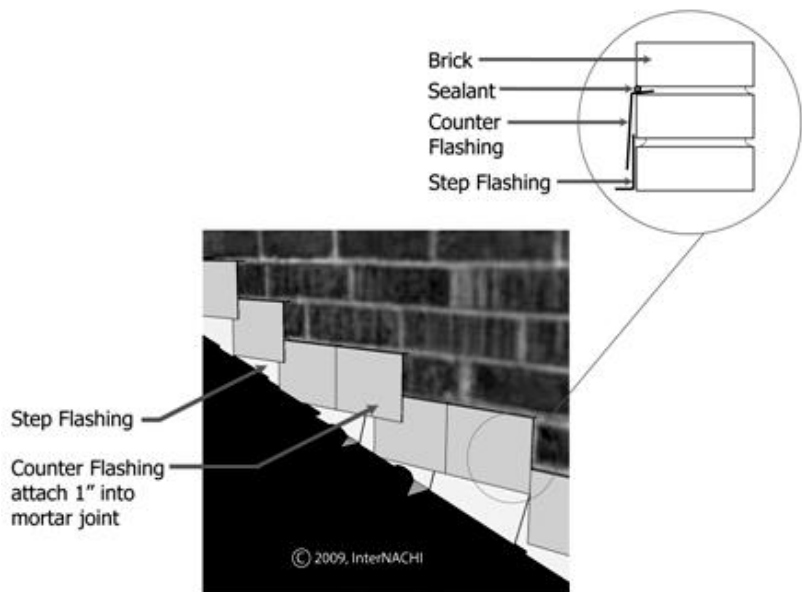

© 2009, InterNACHI

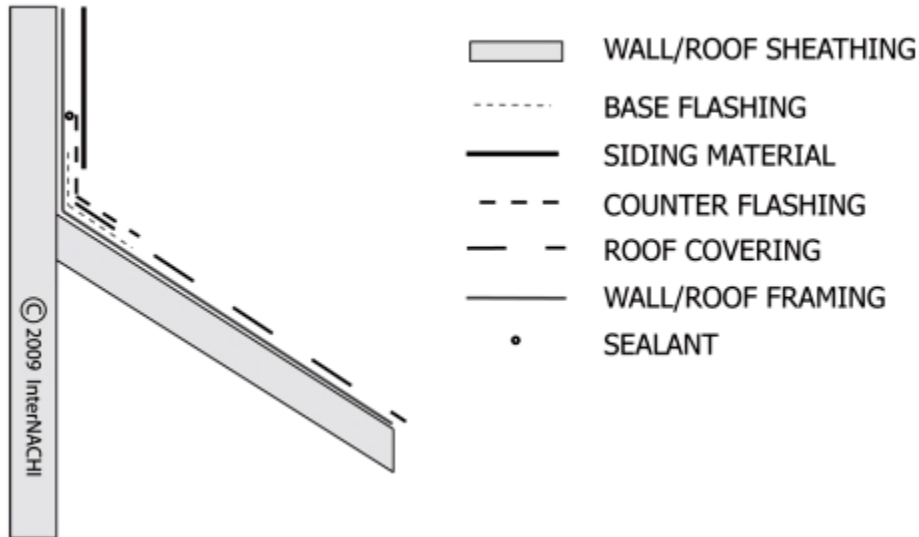

In some cases, the base flashing can be an integral part of the roof covering. This is common with roll and membrane roofing products where the covering can be extended up the wall surface.

In some instances, the siding, in effect, becomes the counter-flashing, such as vinyl siding covering the step flashing on a traditional shingle roof.

When this is the case, the siding should be installed with 1 to 2 inches of clearance to prevent water from wicking into it.

Materials

Obviously, metals are the main choice, with galvanized steel, aluminum, copper and lead all used extensively. Lead is still the most common choice for flashings against masonry, as it is very malleable and retains its shape over rough surfaces.

Shingle-to-Wall Flashings

Most standard shingle types require a small, 9-inch base flashing to be attached at the end of every course where they intersect the wall. These small flashings need to overlap each other by 3 inches minimum, and extend 3 inches up the wall and 3 inches out over the shingle.

Tile-to-Wall Flashings

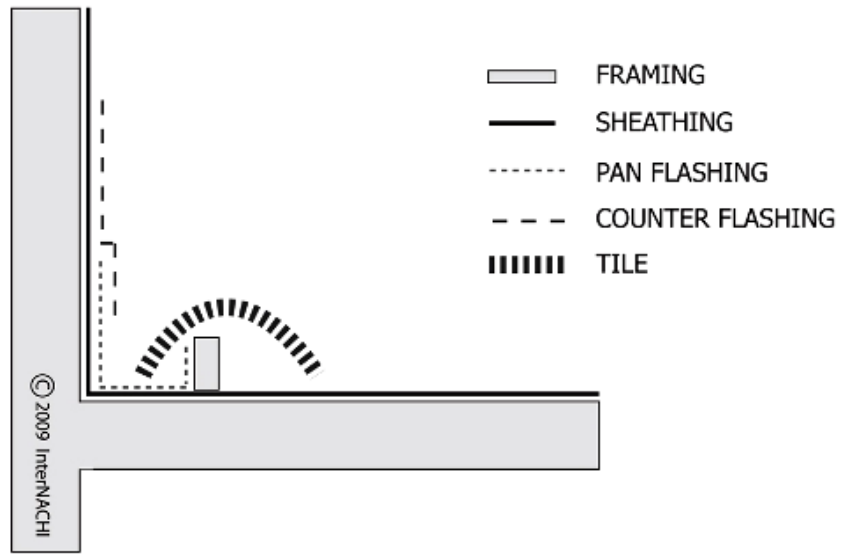

Many roof tiles do not lend themselves to interwoven base flashings due to their complex shapes. In this instance, a pan flashing is installed before the roof tiles are laid down. This is especially common with Spanish style roofs. This flashing is commonly made from galvanized steel, but could be made of any metal. One of the major problems with tile roofs is that the tiles themselves will often outlast the flashings.

Continuous Roof-to-Wall Flashings

Obviously, a continuous roof surface, such as roll roofing, BUR or membrane, needs no step flashing, as such. Very often, the covering is its own base flashing. In this type of installation, one would expect to find a cant strip that transitions the roof covering to the wall.

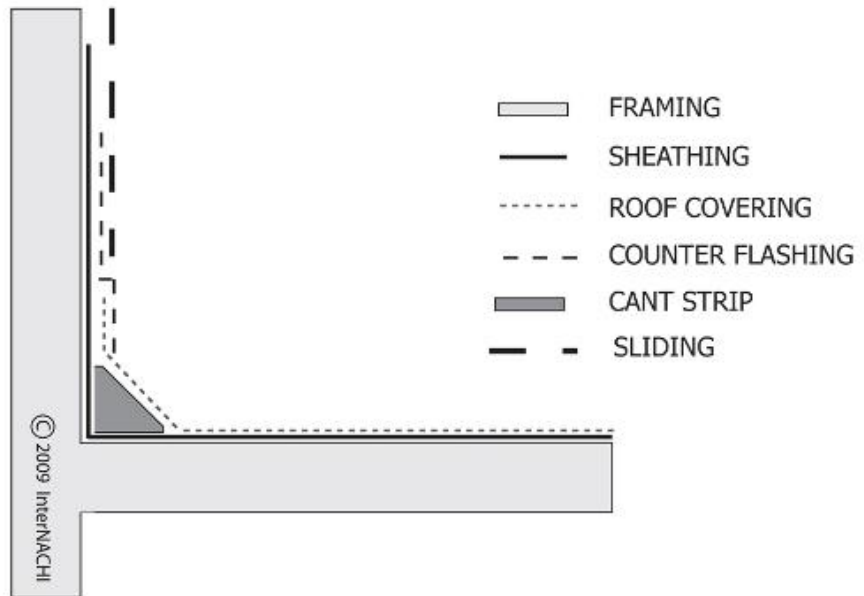

Kickout Flashings

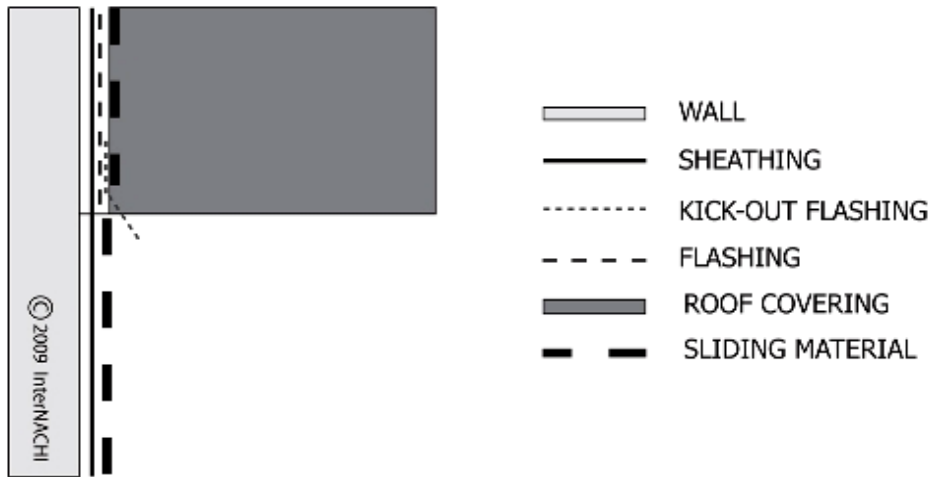

In any location where a roof-wall flashing exists and the roof terminates on the wall, a kickout flashing should be installed.

This flashing is designed to prevent water from running down the flashing and entering the wall system by diverting the flow away from the bottom of the roof-wall interface and to the side outside of the siding material.

CHIMNEY FLASHINGS

Traditional brick chimney flashings and manufactured fireplace flashings are usually quite large and also relatively complex, so the chimney flashings tend to be highly susceptible to moisture intrusion.

Traditional Chimney Flashings

In many applications, the primary chimney flashings are **step flashings**, which can be found between any traditional shingle roof and a vertical surface. The image at right illustrates the most common application of step flashings against a brick chimney.

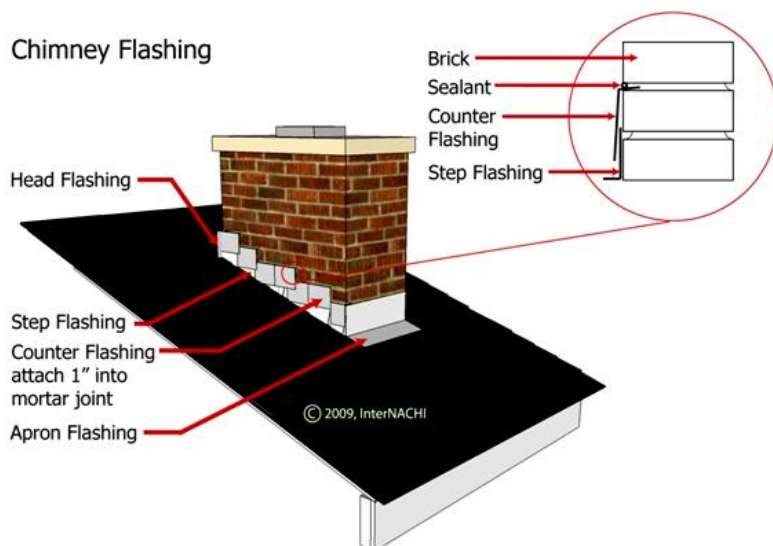

Apron flashings should be at the lowest face of the chimney, directing moisture away from the top-most edge of the shingles or tiles where they abut the chimney.

Head flashings are required on all chimneys less than 30 inches wide. They should be comprised of both a base flashing and a counter-flashing. Ideally, the counter-flashing should extend for about an inch past the sides of the chimney.

When the top-side of the chimney is wider than 30 inches, a **cricket or saddle (a small gable flashing)** needs to be installed. This is used to direct water flow from behind the chimney around to the sides. The size and pitch of the cricket is in proportion to the pitch of the roof and the width of the chimney (see table below).

Chimney Cricket/Saddle Requirements	
Roof Pitch	Height Requirement
12:12	1/2 of chimney's width
8:12	1/3 of chimney's width
6:12	1/4 of chimney's width
4:12	1/6 of chimney's width
3:12	1/8 of chimney's width

For example, a roof of 6:12 pitch with a chimney 42 inches wide would require a cricket or saddle of 1/4 of 42, or 10½ inches high.



Above left: Based on the number of bricks, a chimney cricket should have been installed.

Above right: Tin foil used as a chimney flashing is useless and wrong.

At right: The flashing is missing. The shingles continue up the sides of the chimney and were foamed in place.



VENTS AND OTHER PENETRATIONS

Roof penetrations and flashing

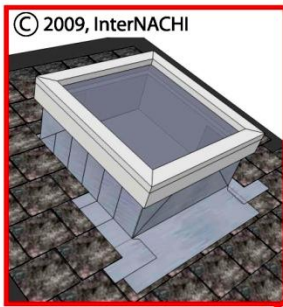

Skylight flashing and shingle application

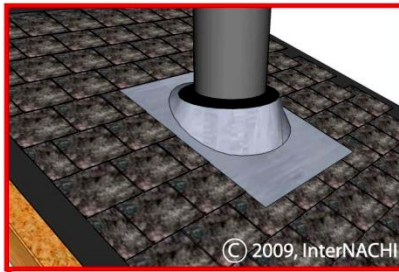

Combustion vent flashing and shingle application

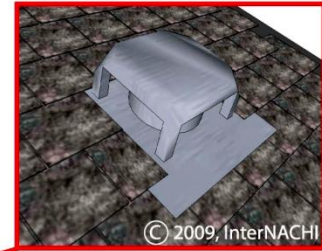

Roof vent flashing and shingle application

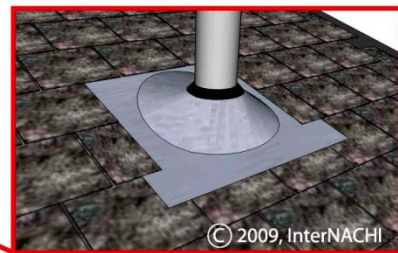
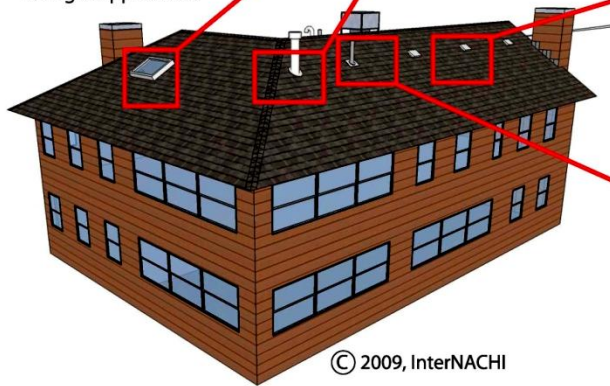

plumbing vent flashing and shingle application

On any roofing system, the most common failures are those associated with any component that projects through the roof covering. In many cases where a roof has been re-covered, the original flashings have either been damaged or re-installed incorrectly, leading to leaks into the interior.

Plumbing Vents

Depending on location, there are primarily two different types of plumbing vent flashing. The most common in northern climates is the neoprene or metal boot. In Florida and in many other southern states, a lead flashing, which also protects the plastic vent pipe from ultraviolet damage, is more common.

Skylights

Most skylights show signs of moisture penetration. This is especially a problem when the roof has been re-covered and the original flashings were damaged while being removed and re-installed.

Through-the-roof dome lights, like the one pictured below, are most commonly retro-fitted and frequently cause leakage problems.





At left: This plastic vent flashing has been installed upside down. This will probably allow moisture to travel down the outside of the vent pipe.

Below: The top of this flashing is not tucked under the seam of the shingle. Water will pour right in. (Courtesy of Homegauge)



Below: This galvanized flashing has been installed improperly. The upper part of it should be under the shingles, and the roofing tar is a further sign of a poor repair.



Below: A skylight in a metal roof shows damage to the roof on the top-side.



Above: This is a plastic vent flashing which was damaged by raccoons.

At right: This flashing has been improperly installed because the base should be underneath the shingles.



QUIZ 6

1. Which of the following materials is not normally used for flashings?

- copper
- timber
- aluminum
- steel

2. The flashing that goes between the roof covering and the sheathing around the roof's perimeter is called _____ flashing.

- drip edge
- rake edge
- counter-

3. A flashing along the peak of the roof is called the _____ flashing.

- valley
- gable
- ridge
- soffit

4. A closed valley means that the valley flashing _____.

- is visible
- cannot be seen
- can be seen from only one side

5. Metal valley flashing should be a minimum of _____ inches wide.

- 30
- 24
- 18

(continued)

6. Traditional step flashing should overlap ___ inches in every direction.
- 6
 - 2
 - 3
7. For most tile roofs, a standard step flashing cannot be used against a wall, so a _____ flashing must be installed.
- pan
 - bucket
 - drip
8. The bottom of a roof should have a _____ flashing where it meets a wall.
- kickout
 - step
 - cornice
9. A secondary flashing that prevents water from entering a base flashing is called a _____ flashing.
- step
 - counter-
 - drip edge
10. The lowest face of a chimney should have a(n) _____ flashing.
- 3-tab
 - apron
 - cricket
11. The flashing around a plumbing vent pipe is called a _____.
- shroud
 - boot
 - sock

Answer Key is on the next page.



Answer Key to Quiz 6

1. Which of the following materials is not normally used for flashings?
Answer: timber
2. The flashing that goes between the roof covering and the sheathing around the roof's perimeter is called drip edge flashing.
3. A flashing along the peak of the roof is called the ridge flashing.
4. A closed valley means that the valley flashing cannot be seen.
5. Metal valley flashing should be a minimum of 24 inches wide.
6. Traditional step flashing should overlap 3 inches in every direction.
7. For most tile roofs, a standard step flashing cannot be used against a wall, so a pan flashing must be installed.
8. The bottom of a roof should have a kickout flashing where it meets a wall.
9. A secondary flashing that prevents water from entering a base flashing is called a counter-flashing.
10. The lowest face of a chimney should have a(n) apron flashing.
11. The flashing around a plumbing vent pipe is called a boot.

ROOF VENTILATION

BASIC VENTILATION

Poor ventilation causes many problems, not the least of which is substantial reduction in the lifespan of asphalt-based roof coverings.

General Venting Requirements

All attic spaces require ventilation at a minimum rate of 1 square foot of venting per 150 square feet of attic area. This may be reduced to 1 square foot of ventilation per 300 square feet of attic space where most of the vents are high on the roof and air flow is induced from a lower point, as is the case with ridge and soffit vents.

The "1-in-300 Rule" may also apply where a vapor barrier is installed on the warm side of the ceiling.

These basic rules apply both to traditional attic spaces and to enclosed areas where the ceiling material is applied directly to the underside of the roof rafters, as one would find with a cathedral ceiling.

The primary reason for these requirements is to allow moisture-laden air to be evacuated from the attic space, and also to attempt to balance the temperature of the roof coverings and sheathing with that of the outside air.

Venting Types

There are many methods employed to achieve adequate venting, among them:

- **gable vents**, which are screened openings in the gable ends, allowing cross-ventilation;
- **turbine vents**, which are wind-powered vents that promote air flow out of the roof area;
- **passive vents**, which are used to provide some air flow between the sheathing and ceiling areas on flat or low-pitch roofs;
- **soffit and ridge vents**, which are installed so air can be drawn from cooler air at the soffit and exhausted through the ridge vents. This style is the most common in new construction and is generally considered to be the most efficient;
- **powered vents** use a thermostat or a switch in the attic space to energize the fan when the attic air reaches a pre-set temperature; and
- **combination venting**, which refers to employing two or more of these methods described, and, in some areas, using through-the-roof vents installed a few feet below the ridge line.



Above: The terracotta pipes shown in this wall are, in fact, part of a passive ventilation system for the flat roof above.



Above: This is the roof outlet for the vent system in the photo at the far left.



Above: This is a turbine vent showing its flashing.



Above: Gable vents come in all styles, so be sure to check that they are merely decorative, especially if there is no other ventilation.



Above: This is an attic fan powered by a solar energy source.

Vent Problems

As with any other system, roof venting may have been installed incorrectly, may not have enough area, may have been rendered inoperable by changes to the home, or may have been badly modified by the homeowner in an attempt to save energy.

Such problems include:

- **a lack of vents.** It is not uncommon to see a complete lack of ventilation. In these cases, the high temperatures within the roof covering will induce a rapid breakdown of the materials. This not only affects asphalt shingle roofs, but also flat and tile roofs that use roll roofing as the primary water barrier. It is also common to find high levels of moisture in these attics, which promotes moisture-related issues, such as rotting sheathing and mold growth.
- **inadequate venting.** Poorly vented roofs will show some of the same issues as roof systems having no venting, but to a lesser extent. Particularly in northern climates, there will be evidence of ice damming and moisture on the roof sheathing. In some cases, inadequate venting will eventually manifest as rusting shingle nails, and even frost on the underside of the roof sheathing in cold weather.
- **too much ventilation.** In some cases, this can be a problem, particularly with large but poorly screened vents that allow rainwater to enter the attic space. The key with ventilation is to strike the correct balance between insulation, moisture barriers and ventilation. A bad installation is, in many respects, worse than none.
- **blocked vents.** Very often, inspectors will see instances of poorly installed insulation blocking the soffit and other vents. These should be reported as in need of repair.
- **false vents.** It is all too common to see what appear to be vents installed that are, in fact, not connected through the structure. Inspectors will sometimes see instances of ridge vents apparently installed, but the roofers did not trim back the roof sheathing along the roof's peak to allow the vents to actually work.
- **damaged vents.** It is recommended that all vents be visually inspected for proper operation wherever possible. Be sure to check to ensure that the flashing system is in good shape and is not leaking. Inspectors will often see vents that have been mechanically damaged, or galvanized vents that are rusting away. These deficiencies should always be reported as in need of repair or replacement.
- **ice damming.** This is typical of poorly insulated vented roofs in colder climates and is caused by snow melting on the roof above the home's heated envelope, and then running down the roof and being trapped by frozen snow and ice above the eaves. The ice will act as a dam and force water to back up under the roof covering, rotting out the sheathing or migrating through into the interior of the structure. The cure for this is an adequate design incorporating proper insulation, ventilation, and an ice and water shield installed under the roof covering in potentially affected areas.



Above: Here is a typical ice dam, causing moisture to back up under the shingles.



Above: Poorly installed insulation is blocking the soffit vents. Also, the baffles are incorrectly installed. (Courtesy of John Hastings)



Above: This kind of damage is a typical sign of previous ice damming in some climates. (Courtesy of Mike Rose)



Above: Someone has covered this turbine with a plastic garbage bag in order to save energy.

Unvented Roof Systems/Attic Assemblies

Spray foam (open- and closed-cell) and fiberglass insulation can perform successfully at unvented roof systems (or unvented attic assemblies) when airtightness is provided and humidity is controlled.

There are many other important factors involved when inspecting unvented roof systems, including: the climate zone; roofing solar and exposure properties; air vapor barriers; and interior humidity levels.

Wood-framed pitched-roof systems are traditionally constructed with fibrous insulation materials installed on the ceiling plane (attic floor) or along the sloped underside of the roof deck. Proper ventilation is critical for these types of systems.

For vented wood-framed pitched-roof systems, the primary concern is the potential for moisture to build up at the sloped underside of the roof deck during cold weather. The underside of the roof deck is the condensing plane.

For unvented roof systems, the condensing plane is the underside of the air-impermeable foam. When they're properly installed, condensation should not exist because the temperature of the interior face of the foam should be about the same as the interior air temperature.

To control airtightness, an air-barrier system must be installed in the roof insulation assembly. An air-impermeable layer may be installed on the inside of air-permeable insulation (such as fiberglass or cellulose) to control both air and moisture movement. For roofs sealed with spray-foam insulation, air leakage is effectively stopped. Failure will be likely via accidental or unintended air flows at unvented wood-framed pitched-roof systems, such as around roof penetrations, including plumbing vents.

Unvented attic assemblies should meet the following conditions:

- The unvented attic space must be completely contained within the building's thermal envelope.
- Interior vapor retarders must not be installed on the ceiling (attic floor) of the unvented attic assembly.
- At wood shingle/shake roofs, a vented air space of ¼-inch should separate the shingles/shakes from the roofing underlayment above the roof deck.
- Air-impermeable insulation can be applied in direct contact with the underside of the roof deck. For Climate Zones 5, 6, 7 and 8, air-impermeable insulation must have a vapor retarder in direct contact with the underside of the insulation.

As long as airtightness is provided and humidity during the winter is controlled, unvented roof systems can perform successfully.

QUIZ 7

1. An attic with an area of 600 square feet with ridge and soffit vents should have a total vent area of ___ square feet.
 - 2
 - 4
 - 6

2. For most roofs, the most effective venting system is _____.
 - powered fans
 - ridge and soffit vents
 - gable vents

3. An attic space with only gable vents should have a vent area of 1 square foot per ____ square feet of floor area.
 - 150
 - 250
 - 650

4. T/F: Roof vents are required for roofs with unconditioned attic spaces.
 - True
 - False

5. Flat roofs normally have _____ venting systems.
 - ridge and soffit
 - gable
 - passive
 - powered

6. T/F: Ice damming is caused by both poor venting and poor insulation.
 - True
 - False

Answer Key is on the next page.

Answer Key to Quiz 7

1. An attic with an area of 600 square feet with ridge and soffit vents should have a total vent area of 2 square feet.
2. For most roofs, the most effective venting system is ridge and soffit vents.
3. An attic space with only gable vents should have a vent area of 1 square foot per 150 square feet of floor area.
4. T/F: Roof vents are required for roofs with unconditioned attic spaces.
Answer: True
5. Flat roofs normally have passive venting systems.
6. T/F: Ice damming is caused by both poor venting and poor insulation.
Answer: True



INSPECTING CHIMNEYS

MASONRY CHIMNEYS

A visual inspection of the outer chimney structure should be performed along with inspection of the roof covering.

On most homes, the chimney will usually be the largest projection through the roof, or the component with the longest flashed area abutting the roof. Proper flashings, therefore, are of the utmost importance. Also, the structure should be inspected for signs of moisture intrusion and failure.

CHIMNEY EXTENDERS

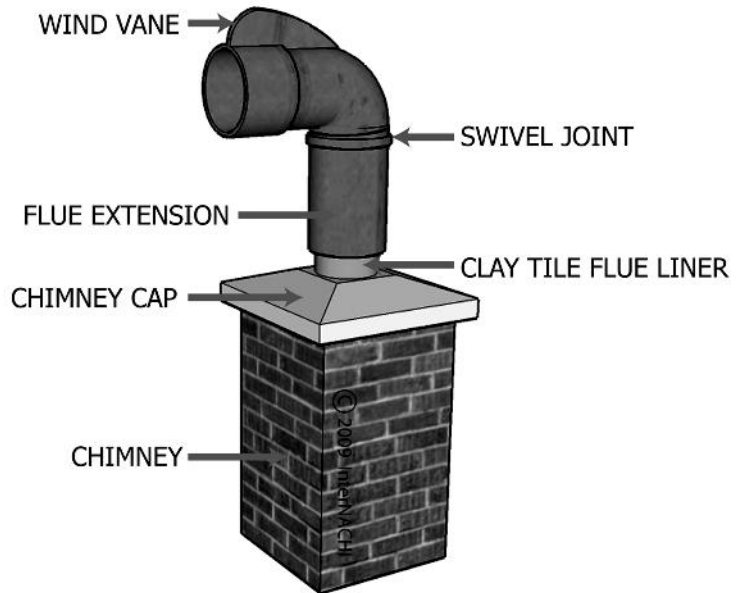

General Chimney Requirements

All chimneys are required to meet a minimum standard for height above the roof coverings. The basic rule for this is:

**a minimum of 3 feet high,
as well as 2 feet higher than any roof
within 10 feet horizontally.**

Masonry Structures

Most chimneys are manufactured with brick, stone or concrete blocks, some of which may be part of a manufactured chimney system. All chimney systems should be visually inspected for signs of deterioration, which can lead to moisture intrusion of the chimney system.

Masonry Failures

Masonry systems are not maintenance-free and will fail over time. The most common failures are those related to weathering of either the masonry itself or the mortar that holds it together. Deterioration of the masonry or the mortar will allow moisture into the chimney structure, accelerating other problems. It's common, particularly in the northern United States, to see brick work that is missing its face.

This is caused by moisture saturating the brick and then freezing, pushing off the front face. Once this has happened, the brick will erode very quickly because the inside of the brick is relatively soft.

Inspectors will also see signs of the mortar failing in the joints between the bricks. This happens as the mortar breaks down and becomes powdery. The cure for this is to have a mason scrape out the affected mortar and replace it with fresh mortar. This process is called re-pointing. Erosion of the brick and mortar is called spalling.



*Above: This chimney has not been maintained at all, leading to a full collapse.
(Courtesy of Jeff Pope)*



*Above: A block chimney is showing such severe cracking that the top three courses are completely loose.
(Courtesy of Joe Myers)*



Above: A brick is missing and the mortar is spalling out.

Chimney Crown Failures

All chimney systems should have crowns installed. They serve two purposes. First, they seal the area between the chimney flue and the masonry structure, preventing rainwater from running down the outside of the flue within the chimney. Second, the crown generally extends beyond the masonry structure so that the water drips off the edge, rather than wicking into the brick or block work. The chimney crown, which is usually made of poured concrete, should be pitched downward, away from the chimney flue.



Above: This chimney has no cap or liner all. It is no longer legal to build an unlined chimney.



Above: Cracking can be seen both in the liner and in the chimney cap. This damage was caused by a flue fire.



Above: cracking in the chimney cap

Rain Caps

A rain cap should not be confused with a chimney cap. A rain cap is installed to protect the inside of the chimney flue from both weather and wildlife intrusion. In some cases, a rain cap can also be helpful in preventing downdrafts into the flue. It is also not uncommon to see a rain cap acting as a damper for a traditional fireplace.

Rain caps are always manufactured out of metal. The best-quality ones are made from stainless steel or copper. Many are manufactured from galvanized steel, which tend not to last as well in-service and will frequently rust out. Some jurisdictions also require rain caps that incorporate spark arresters, especially in arid regions where wildfires are relatively common occurrences.



Above: The flue on the left has been sealed with concrete, and the flue on the right has a rain cap. However, the chimney cap itself is cracked and the brick work is showing signs of efflorescence.



Above: This rain cap is completely choked with creosote, which is not unusual to find when the homeowner has been burning unseasoned timber.



At left: A specially designed copper rain cap protects this double-flue chimney.

Chimney Flues

While the inspection of chimney flues is a highly specialized procedure, any obvious deficiencies in the flue should be noted. In particular, pay attention to flues that are damaged, collapsed, or show signs of previous chimney fires. Extra care must be taken when inspecting chimney systems that are being used to vent fossil-fuel appliances, such as boilers, furnaces, water heaters and manufactured fireplaces, as any deficiency in either the liner or the chimney structure could be a potential fire starter, or could allow carbon monoxide into the habitable space within the home. It is now required that any traditional flues being used as vents for these appliances be fitted with continuous metal flue liners to ensure that no noxious gases can find their way into the home.



Above: This is the view down an unlined chimney flue. Vegetation is growing through it, and a bird has built its nest in it, too.



Above: This chimney flue has poorly done brick work and is filled with debris. (Courtesy of Joe Myers)



At left: This flue has collapsed due to a chimney fire. The installation of two flues not separated by a brick divide would no longer meet code for new construction.

The home inspector should evaluate and report on the following:

- the material that the chimney is made of;
- the condition of the chimney stack;
- the visible condition of the flashings;
- the condition of the chimney cap;
- the condition of the rain cap (if installed); and
- that the chimney meets minimum height and safety requirements.

MANUFACTURED CHIMNEYS

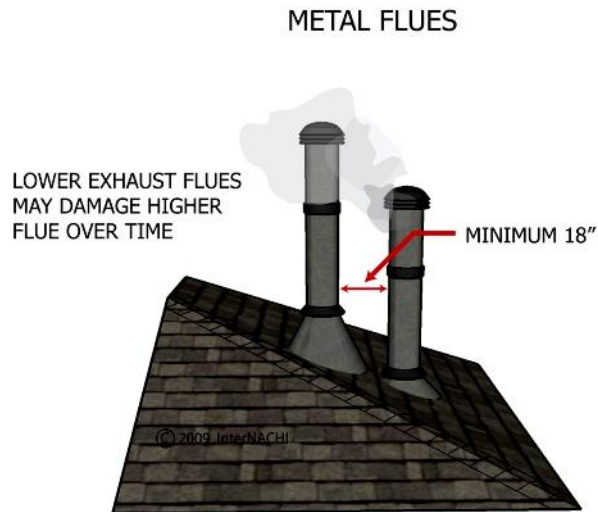

The term "manufactured chimney" generally relates to prefabricated chimney components, as opposed to a traditional chimney that would normally be manufactured from masonry products.

In most new housing, a manufactured chimney typically consists of a steel vent or flue built inside an artificial chimney stack. For the most part, the clearance requirements are the same as for any other chimney system; however, special attention must be paid to the proper clearance of combustibles where the chimney or vent passes through the roof covering.

General Chimney Requirements

All chimneys are required to meet a minimum standard for height above the roof coverings. The basic rule for this is exactly the same as for the traditionally built chimney:

**a minimum of 3 feet high,
as well as 2 feet higher than any roof
within 10 feet horizontally.**

Timber Structures

In most cases, a manufactured chimney flue is covered over with a timber frame structure, and finished in a siding material to match the rest of the property, or a stucco, traditional brick, or masonry veneer covering the structure.

Any failure of the system will allow considerable moisture to enter the general framing of the structure, so it is vital to pay particular attention to any and all flashing systems related to the chimney. In many cases, especially those chimneys that are sided with traditional timber siding, the inspector must ensure that there is at least a 1- to 2-inch clearance between any wooden components and the roof covering.

Carefully inspect the areas of the chimney that abut the roof covering, as there will often be considerable signs of dampness.



In this poorly designed chimney at left, there is no separation between the timber components and the roof, and there are a couple of dead areas which will trap moisture and promote rot.

Chimney Caps

Normally, a manufactured chimney has a metal chimney cap to prevent water from entering the structure between the flue and the framing. Inspectors will often find that this flashing has failed due to moisture ponding on the cap, resulting in rust through this flashing. The rain cap should incorporate a drip edge similar to what one would expect to find under any roof covering. This is required to deflect water away from the vertical sides of the chimney.



At left: Water is ponding on the top of the chimney cap. This will cause it to rot very quickly. Also note the lack of a proper drip edge.

Rain or Termination Caps

Most manufactured chimneys are supplied with rain caps or deflectors built to the manufacturer's specifications. In many areas, these caps or deflectors are required to be installed with spark arresters to prevent sparks from leaving the flue. These are usually manufactured from either aluminum or galvanized steel, and are susceptible to mechanical damage, rusting, and galvanic reaction between dissimilar metals.

Proper Clearances

Due to the fact that all manufactured chimneys have metal flues which conduct heat very efficiently, it is important that proper separation is maintained where the flue passes through any ceiling-floor structures, as well as through the roof sheathing. The minimum acceptable clearance is 2 inches. It is required that an approved thimble is used where the vent goes through the roof sheathing and covering in order to maintain the 2 inches of separation and prevent moisture entry at this point.



At left: This is a manufactured chimney going through the roof sheathing. The clearance on the right side is probably less than 2 inches. Also, notice how the rafter has been cut.

At right: This is a manufactured chimney without any faux covering. The thimble is acting as both clearance and weatherproofing.



When inspecting manufactured chimney systems, the inspector should pay particular attention to:

- the material that the structure is built from;
- the type of covering;
- any signs of moisture entering the covering or structure;
- the condition of the flashings;
- the condition of the chimney cap;
- the condition of the rain cap or deflector;
- the clearance from combustibles (where visible); and
- the height clearances to adjacent structures.

QUIZ 8

1. The minimum height for a traditional chimney is ___ feet.
 - 2
 - 3
 - 4

2. If a roof ridge is closer than 10 feet to a chimney, the stack should be ___ feet higher.
 - 2
 - 3
 - 10

3. Flaking or powdering of masonry or mortar is called _____.
 - spalling
 - pointing
 - efflorescence

4. The process of repairing missing mortar between brick joints is called _____.
 - mudding
 - grouting
 - re-pointing

5. The difference between a chimney cap and a rain cap is _____.
 - a rain cap protects the structure, and a chimney cap protects the inside of the flue
 - a chimney cap protects the structure, and a rain cap protects the inside of the flue

6. T/F: All chimneys should have a spark arrestor fitted.
 - True
 - False

(continued)

7. A clearance gap of ___ inches is required between a manufactured chimney and combustibles.
- 3
 - 2
 - 6
8. T/F: A rain cap or deflector is required on all manufactured chimneys.
- True
 - False
9. The proper name for the connection between a manufactured chimney flue and the roof is called a _____.
- boot
 - bucket
 - thimble
10. T/F: Manufactured chimney systems are not required to maintain the same separation from adjoining structures as traditional chimneys.
- True
 - False

Answer Key is on the next page.

Answer Key to Quiz 8

1. The minimum height for a traditional chimney is 3 feet.
2. If a roof ridge is closer than 10 feet to a chimney, the stack should be 2 feet higher.
3. Flaking or powdering of masonry or mortar is called spalling.
4. The process of repairing missing mortar between brick joints is called re-pointing.
5. The difference between a chimney cap and a rain cap is a chimney cap protects the structure, and a rain cap protects the inside of the flue.
6. T/F: All chimneys should have a spark arrestor fitted.
Answer: False
7. A clearance gap of 2 inches is required between a manufactured chimney and combustibles.
8. T/F: A rain cap or deflector is required on all manufactured chimneys.
Answer: True
9. The proper name for the connection between a manufactured chimney flue and the roof is called a thimble.
10. T/F: Manufactured chimney systems are not required to maintain the same separation from adjoining structures as traditional chimneys.
Answer: False



Above: a clay tile roof ridge, which is not continuous, so the gap should be sealed



Above: a standard asphalt ridge being installed

Below: This is a wood shingle ridge showing how the shingles lap. Note the use of staples to fasten them.





**InspectorOutlet.com is your source for
all things inspection-related!**



We are the official source for InterNACHI, the International Association of Certified Home Inspectors (www.NACHI.org).

We strive to provide the lowest prices on the highest-quality tools, products, supplies, safety apparel and equipment, as well as educational books, articles and marketing materials to help home and commercial property inspectors stay on the cutting edge of the inspection industry.

"Inspector Outlet is officially endorsed by InterNACHI for the best prices in the business for our members."

-- Nick Gromicko, Founder of InterNACHI

At InspectorOutlet.com, we are constantly expanding and adding new products, so check our site often. If there is something you would like to see in our store, please feel free to email us with your suggestions.

***We appreciate your business,
and we're here to help you find what you need!***